

# Comfort 140

## Installation Instructions



 SYSTEM<sup>®</sup>  
TOTALINE

Please follow the installation and fitting instructions carefully to avoid wrong installation or damage to the door and door operator. Keep these instructions for later reference.

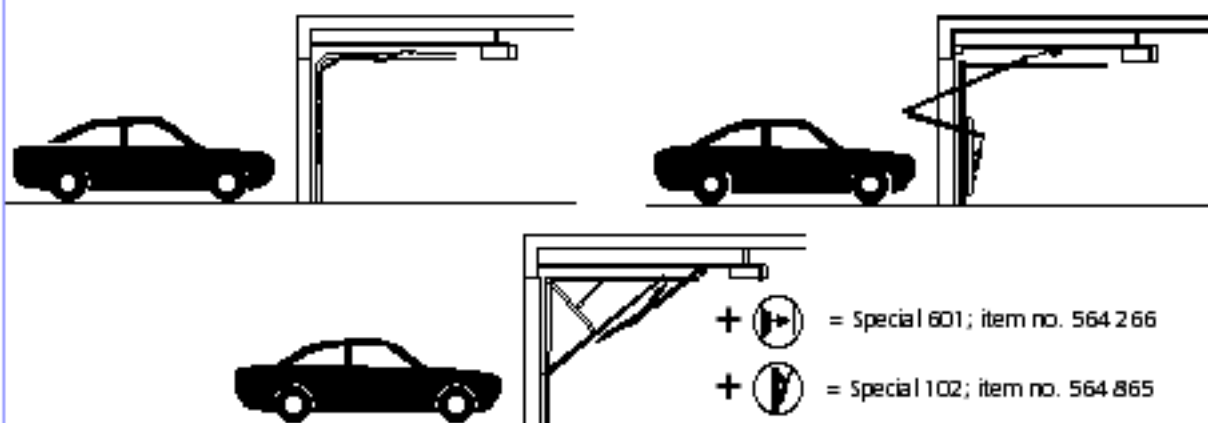

1

Unpack the boom, motor housing and accessories ready for installation.

2

The following tools are required:

combination wrench SW 10  
combination wrench SW 13  
Socket wrench SW 10  
Socket wrench SW 13  
screwdriver, size 8  
screwdriver, size 5  
Phillips screwdriver, size 2  
masonry drill 10 mm dia.  
masonry drill 6 mm dia.  
metal drill 5 mm dia.  
pliers  
hack saw  
electric drill

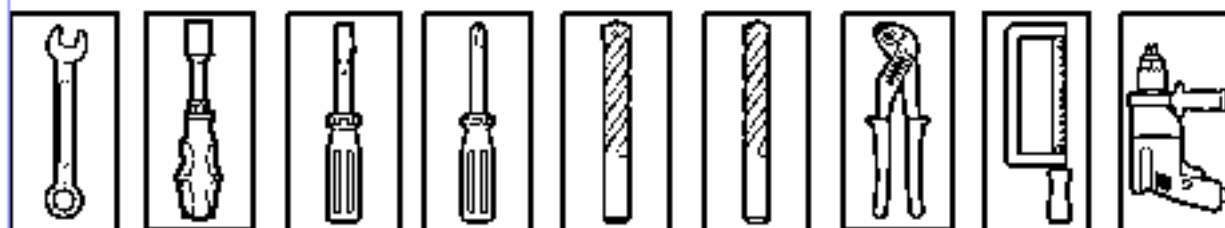

**Important!**

Before drilling, cover over the motor with foil, film or cardboard.  
Drilling dust and chippings can lead to malfunctions.

3

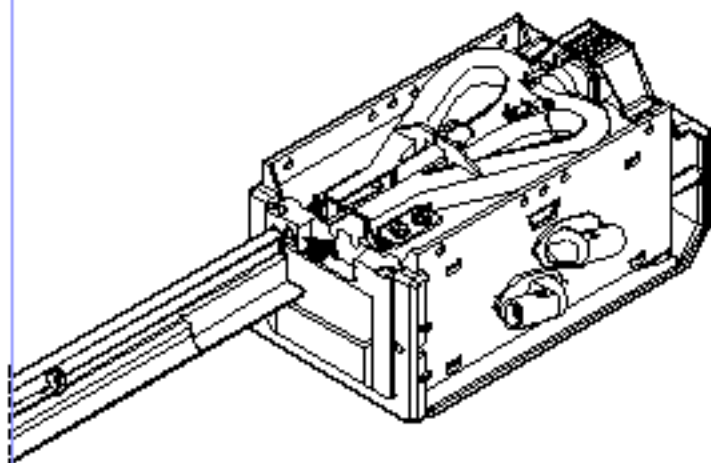

Slide the boom into the motor housing.

Screw the supplied centering screws (A) through the boom into the motor housing.

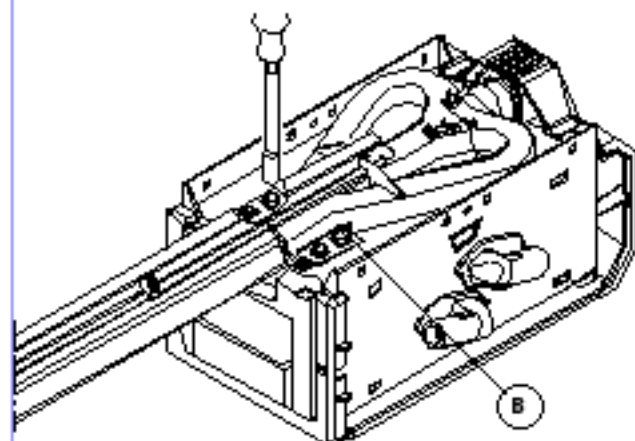
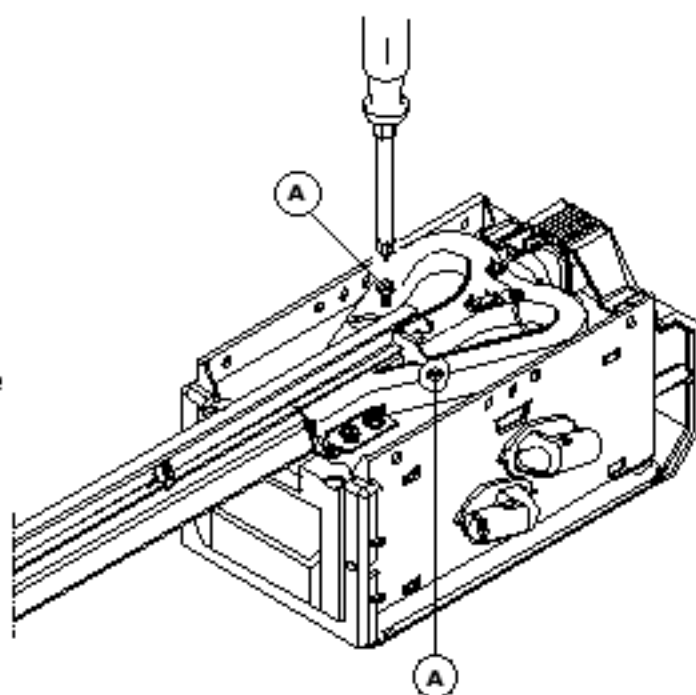

Screw on the 4 setscrews (B) tightly.

4

Grease the carriage bearers on all sides.  
Push lever (A) and forward slide the carriage onto the boom  
before moving the lever (A) back to normal.

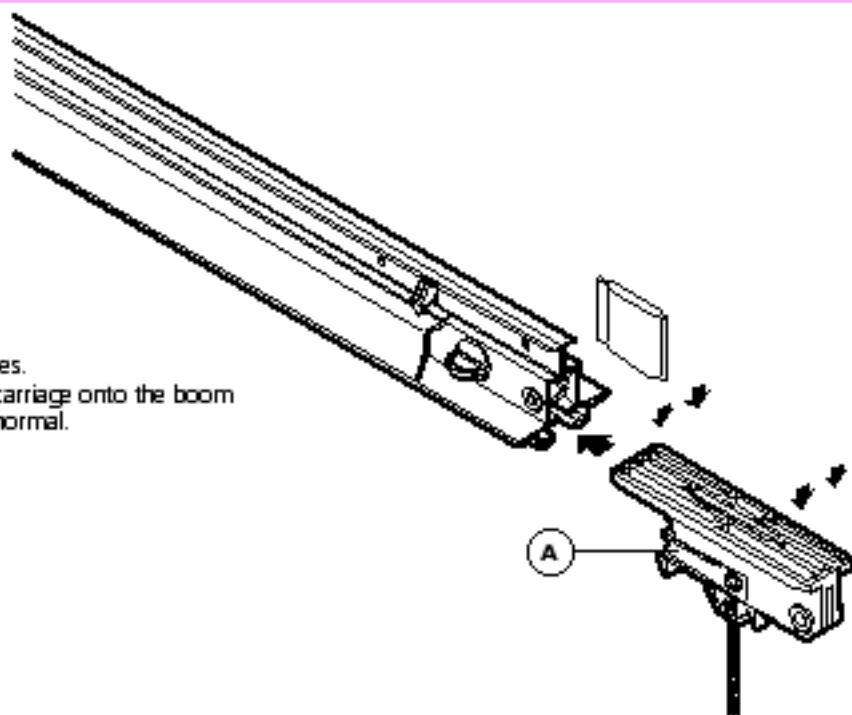

5

Remove the locking pin (B).

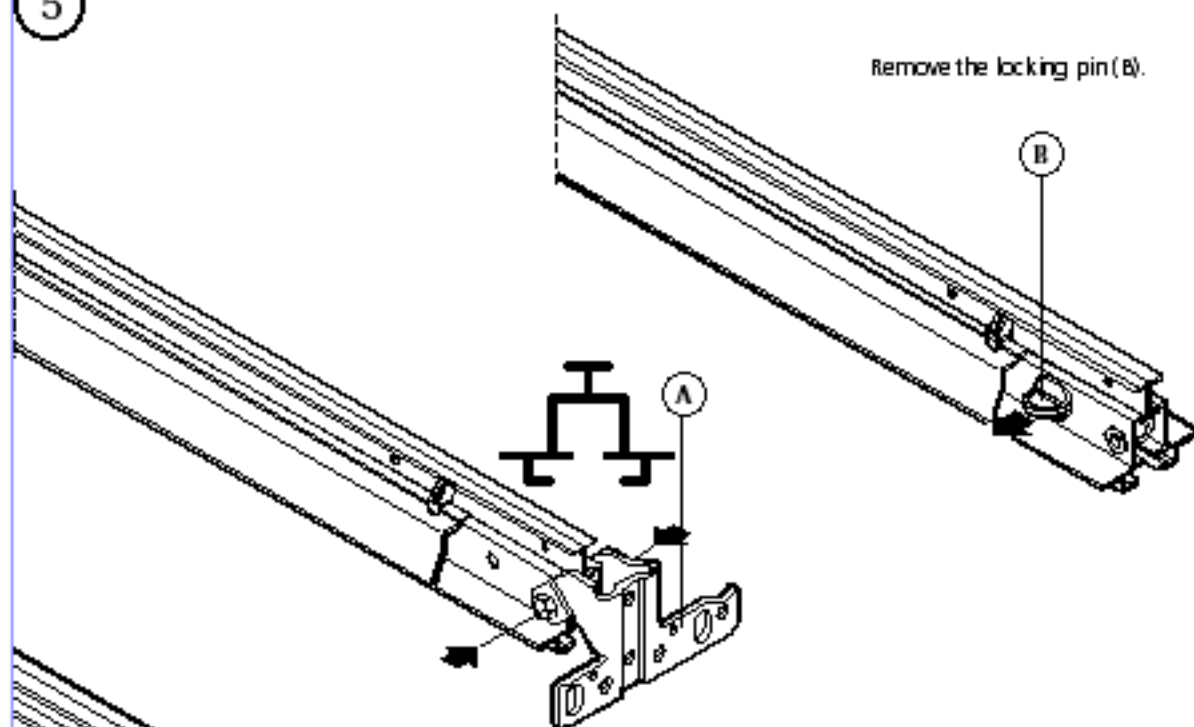

Screw the wall bracket (A) onto the boom.

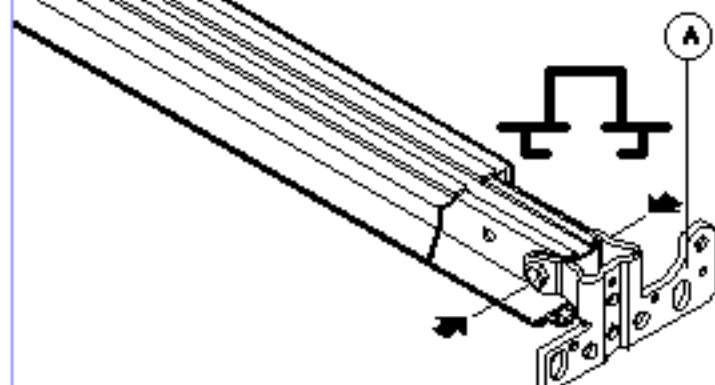

6

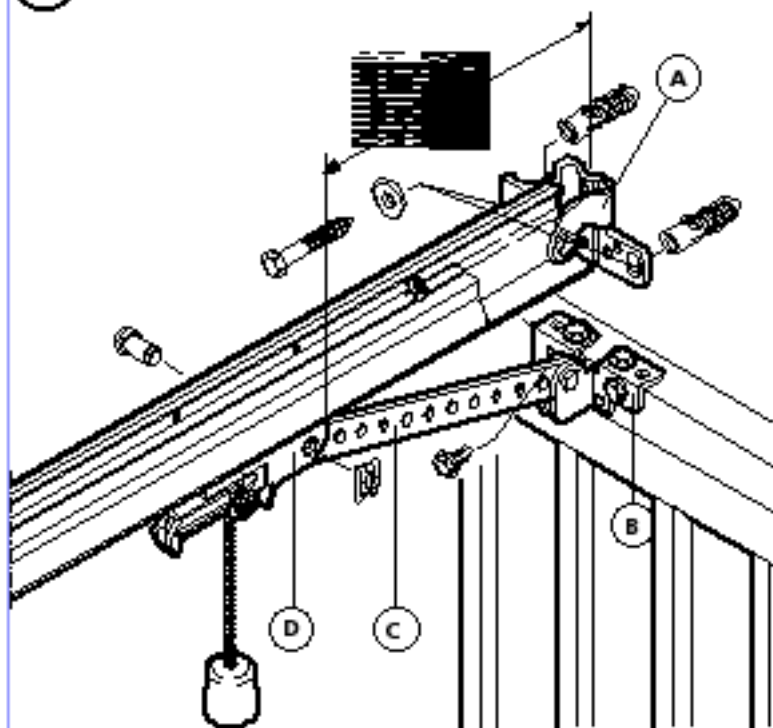

### Up-and-over doors:

Screw wall bracket (A) with boom onto the top surrounds or lintel. Make sure that the door at its highest point of opening clears the bottom edge of the boom by 10 mm (see fig. 10).

Screw the door link bracket (B) onto the top edge of the door (5 mm dia. drill). Connect the door link (C) to the carriage (D) and the door link bracket (B).

If the on-site installation situation does not allow a minimum distance of 165 mm to be adhered to, an extended door link must be used.

Remove door locks or put them out of operation.

7

### Sectional doors:

Sectional door fittings are required: item no. 564 611 (not included with Comfort 140).

I Fit the wall bracket (A) with boom to the lintel with wall plugs, positioning the top door section at its highest point of opening to clear the bottom edge of the boom by 10 mm (see fig. 10).

II Fix the adjustable door connector attachment (B) to the top door section. For steel sections, use a 5 mm dia. drill.

- If necessary, the drive unit can be installed 200 mm off-centre.
- For wooden sections, use the supplied wood screws.

III Connect the 2-piece door link (C) to the carriage (D) and door connector attachment (B).

If the on-site installation situation does not allow a minimum distance of 165 mm to be adhered to, an extended door link must be used.

Remove door locks or put them out of operation.

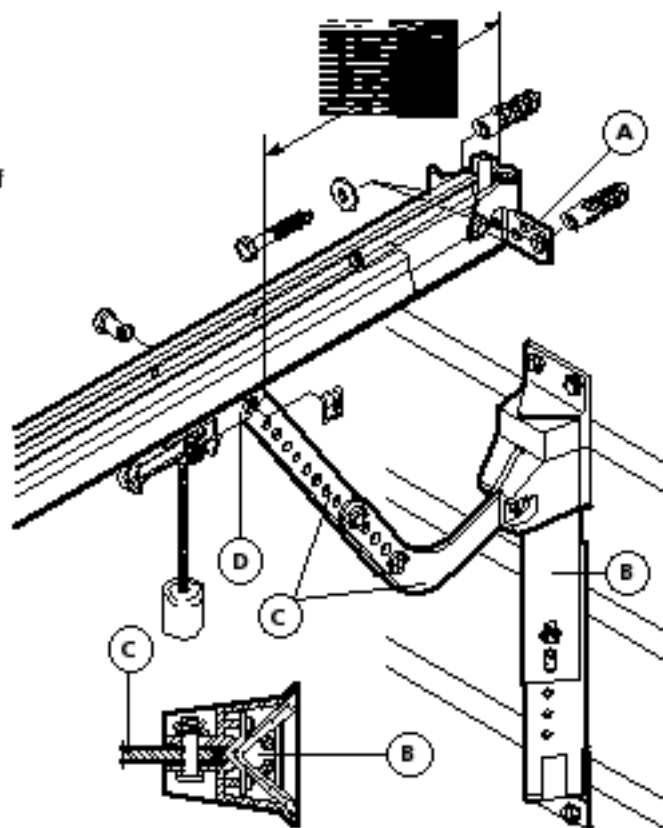

8

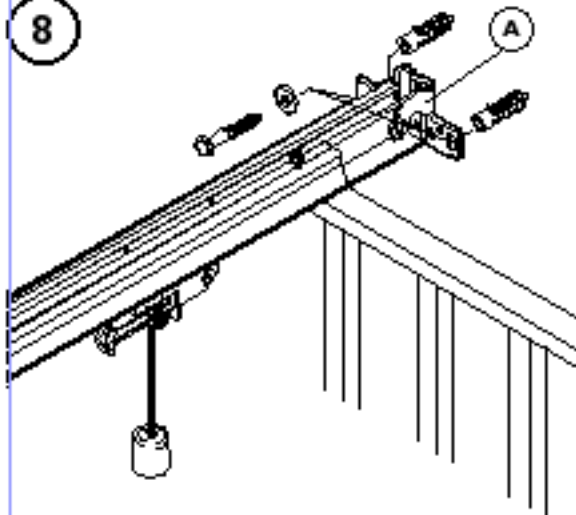

### Canopy and non-protuding up-and-over doors:

Special 102 adapter arm, item no. 564 865 and Special 601 photocell, item no. 564 266 are required (not included with Comfort 140).

Before installing the drive unit, remove the door locks or put them out of operation.

Screw the wall bracket (A) with boom to the lintel or top of the door surround in such a way that the top edge of the door at its highest point of opening clears the bottom edge of the boom by at least 10 mm (see pt. 10).

Until the ceiling mounts are subsequently fitted, support the drive unit housing using a trestle or other suitable object.

### Fitting the adapter arm:

Screw support bracket (B) with 6 self-tapping screws to the top edge of the door (5 mm dia. drill hole).

The support bracket and boom meet centre to centre.

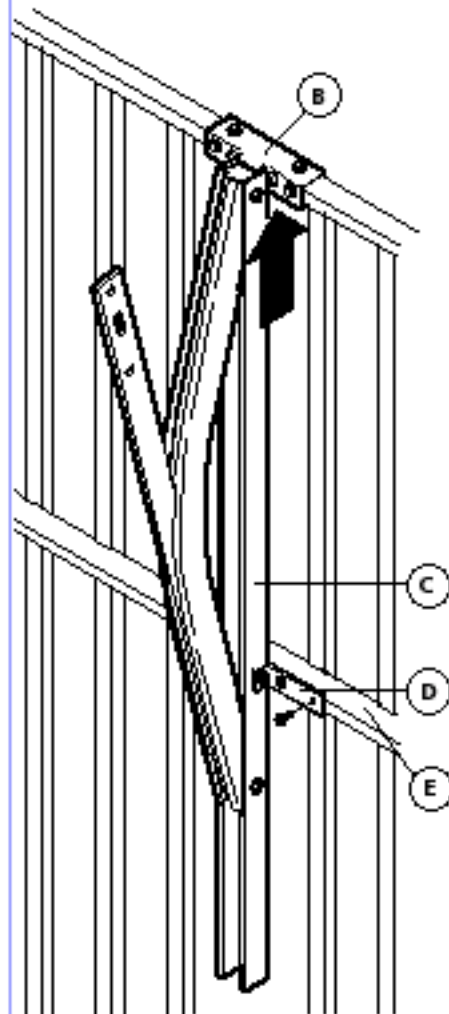
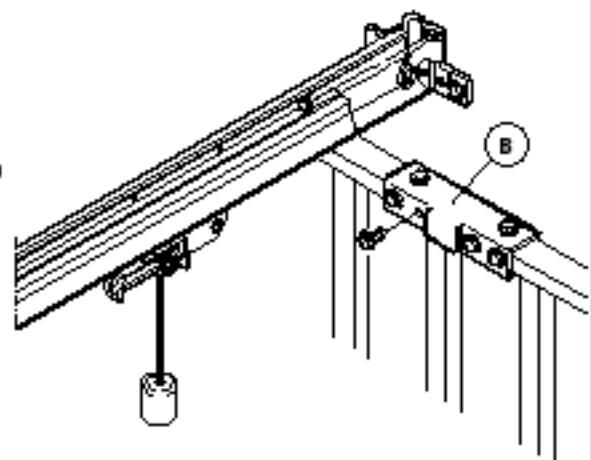

Slot adapter arm (C) into support bracket (B) and using two angle plates (D) screw to the cross struts of the door (E).

(5 mm dia. drill hole) in the door cross struts (4x)

(7 mm dia. drill hole) in the adapter arm (2x).

The angle plates are screwed to the adapter arm using two M6 x 10 screws and hex nuts.

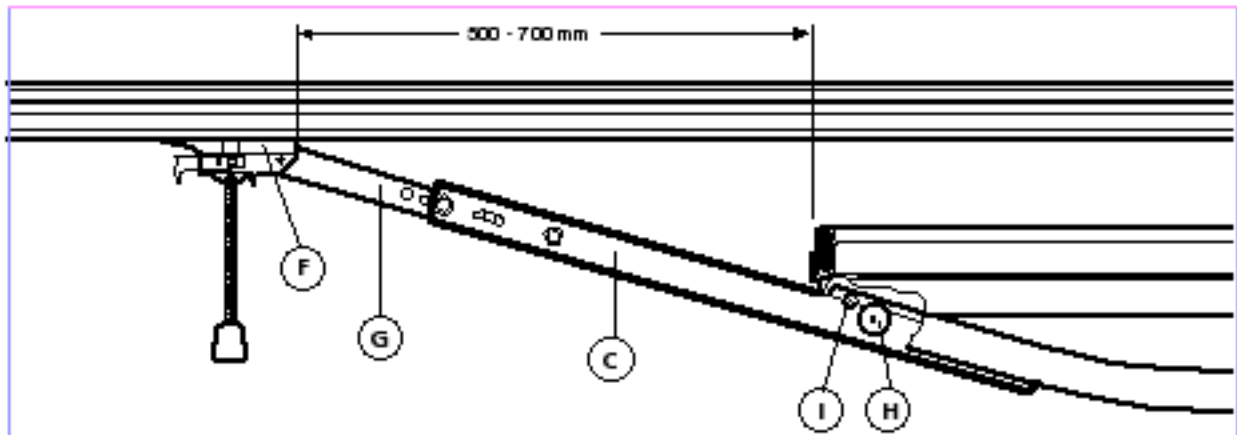

Open the door fully, connect carriage (F) and linking bar (G) to the adapter arm (C) observing the given dimensions. By lowering the carriage and extending the linking bar, the door opening is enlarged. The linking bar may only be pulled out to the extent that the internally located pressure rollers (H) do not abut against the check screws (I).

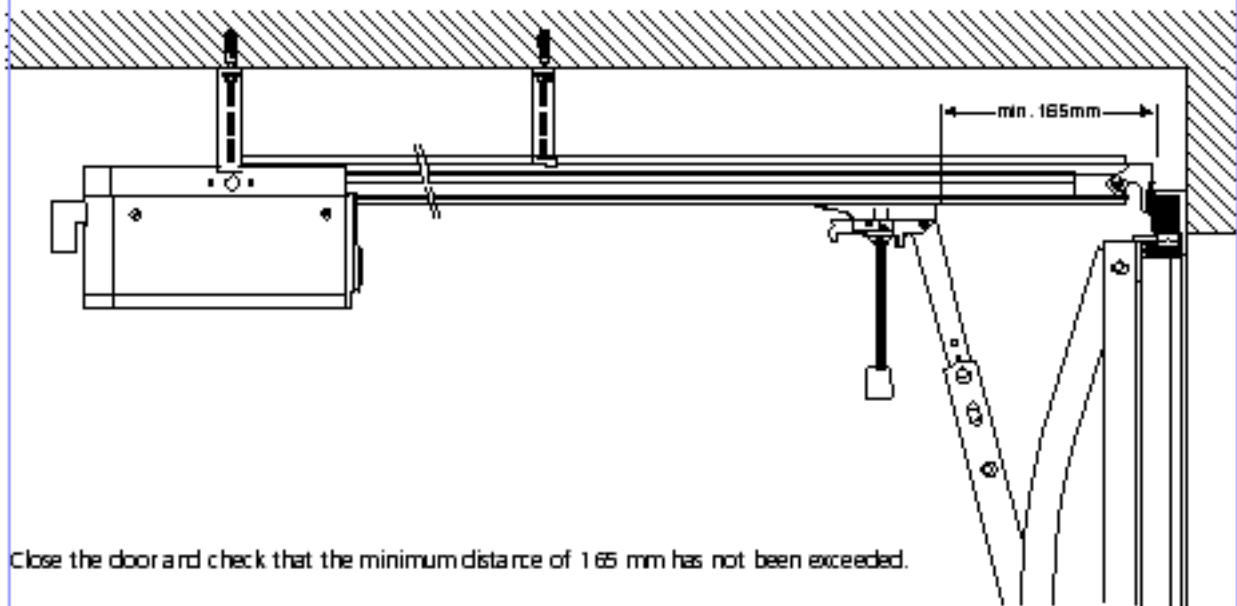

Close the door and check that the minimum distance of 165 mm has not been exceeded.

To ensure optimum operation of the drive unit and door, the door travel speed should be altered to 8 cm/s.  
See point 11 of the Installation Instructions.

9

Bolt on the 2 support straps (A) to the motor housing. Bend them according to site requirements and saw off the projecting lengths (see fig. 10).

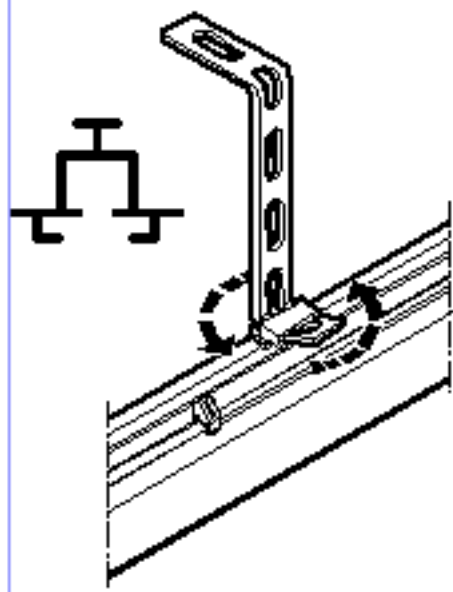
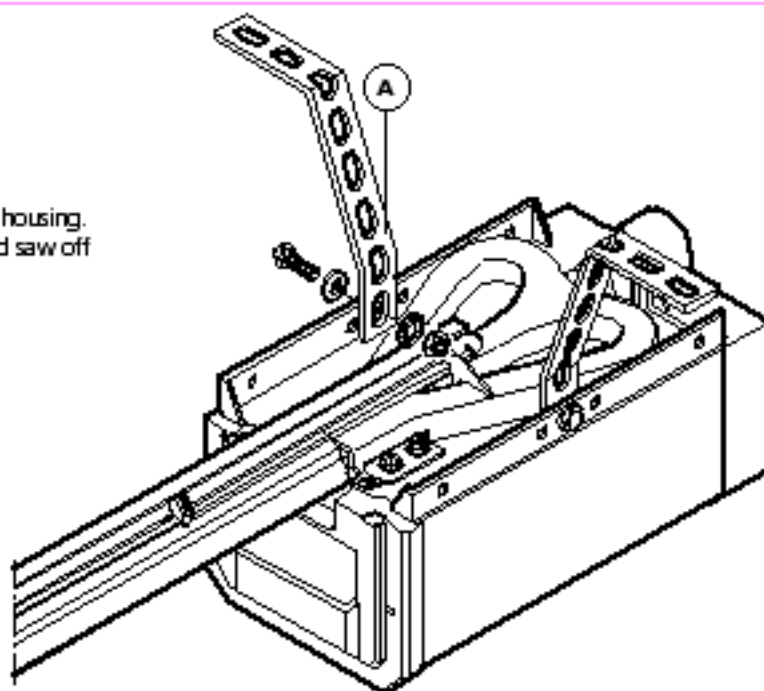

Attach one support strap to the middle of the boom.

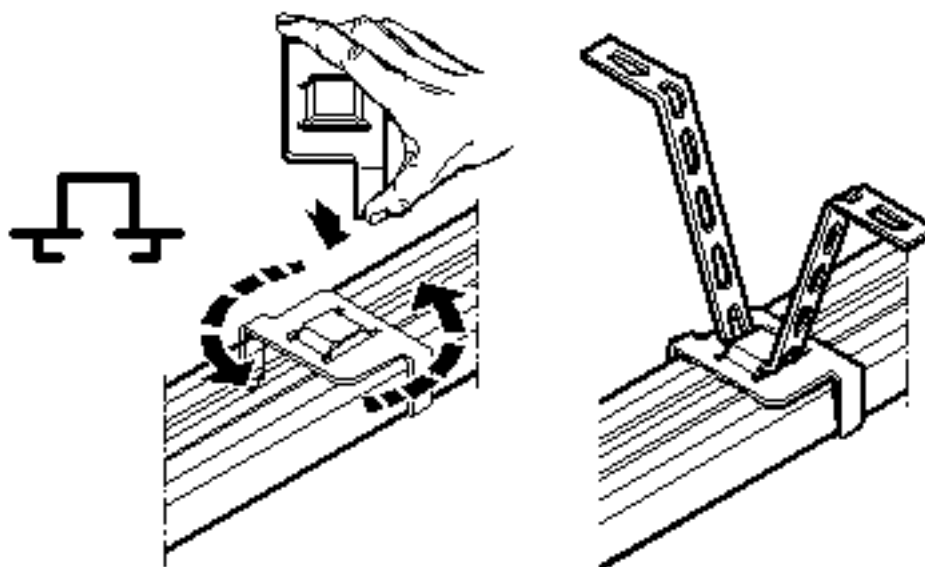

10

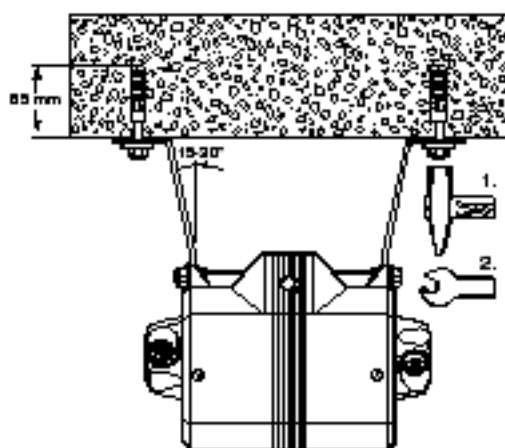
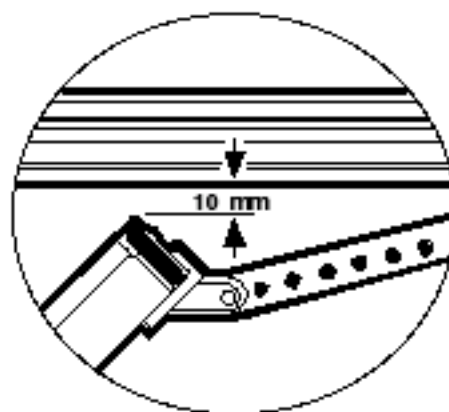
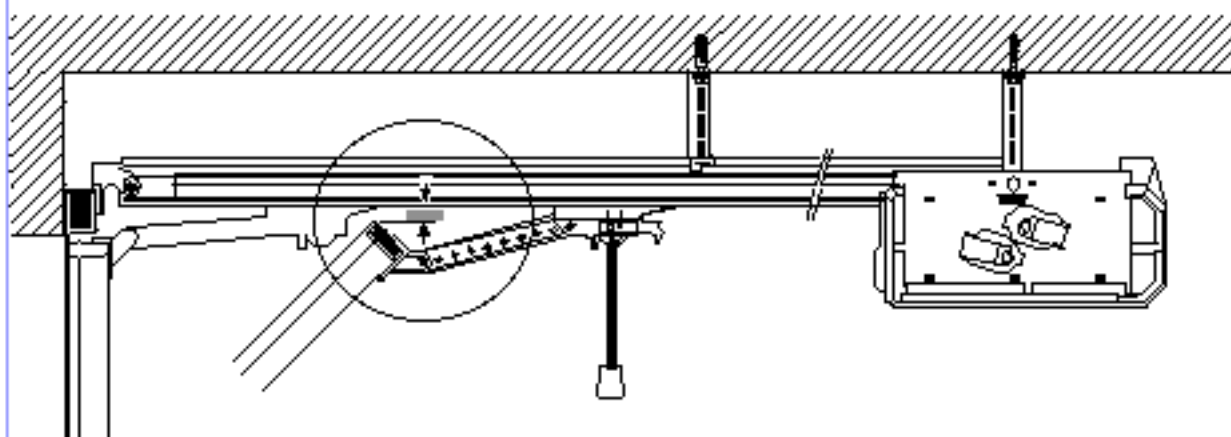

Bolt the motor housing with boom onto the ceiling, making sure that the top edge of the door at its highest point of opening clears the bottom edge of the boom by 10 mm (see figs. 6 and 7). Install the ceiling mounts as constructional features of the garage allow (note drill depth for wall plug).

11

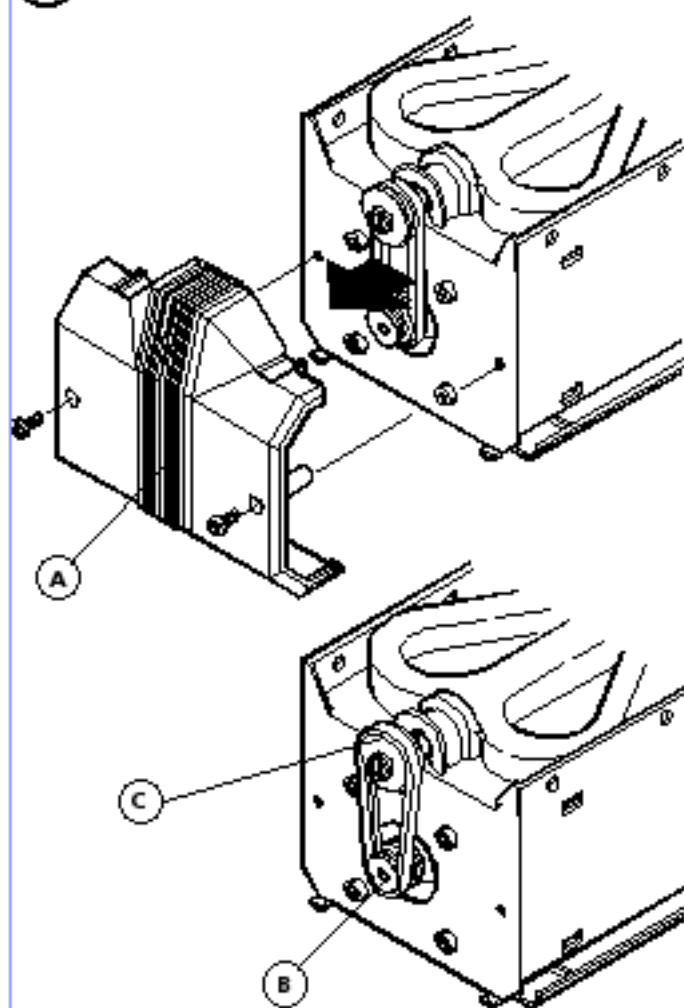

Altering the door travel speed for large doors and canopy and non-protuding up-and-over doors.

**Only to be carried out by a specialist!**

The drive unit is supplied set for the faster door travel speed of approx. 14 cm/s.

By relocating the drive belt, the door travel speed can be reduced to approx. 8 cm/s.

Unscrew and detach the rear cover (A). Slip the drive belt first over the small lower motor pulley (B), then over the large upper spindle pulley (C). Do not use any sharp-edged tools.

12

Screw in four light bulbs (max. 40 Watt) and clip on the lamp cover. After impulse operation, the light bulbs stay on for approx. 3 minutes.

Light bulbs are not covered by the guarantee.

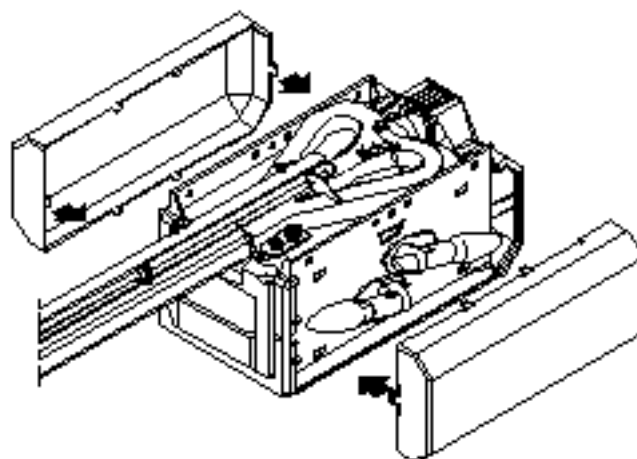

13

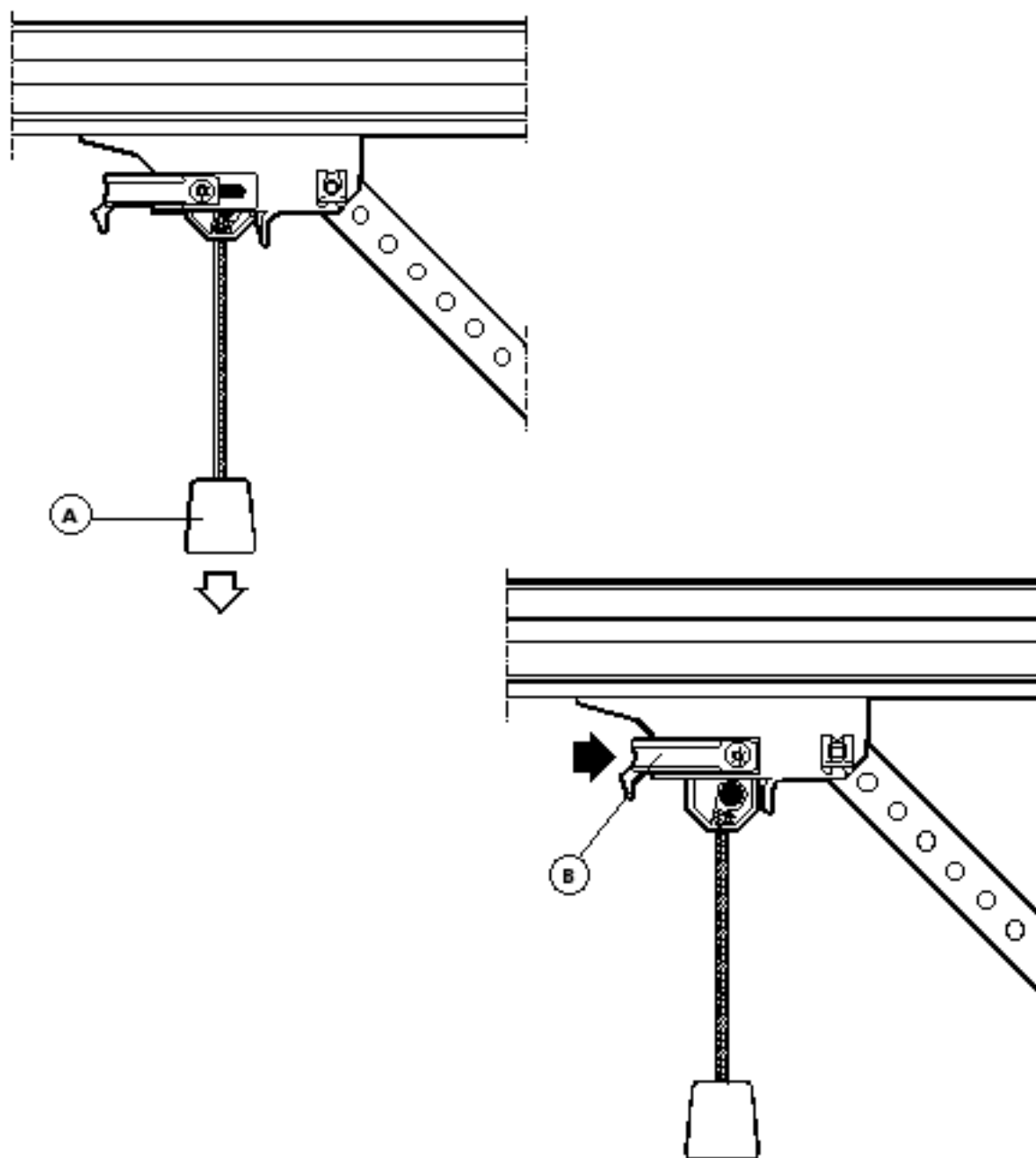

**Quick release:**

Pull the cord knob (A) to separate the door from the drive. When an impulse is given whilst the door is released, the carriage will automatically re-engage. For a permanent separation of door and drive, pull lever (B) fully forward.

14

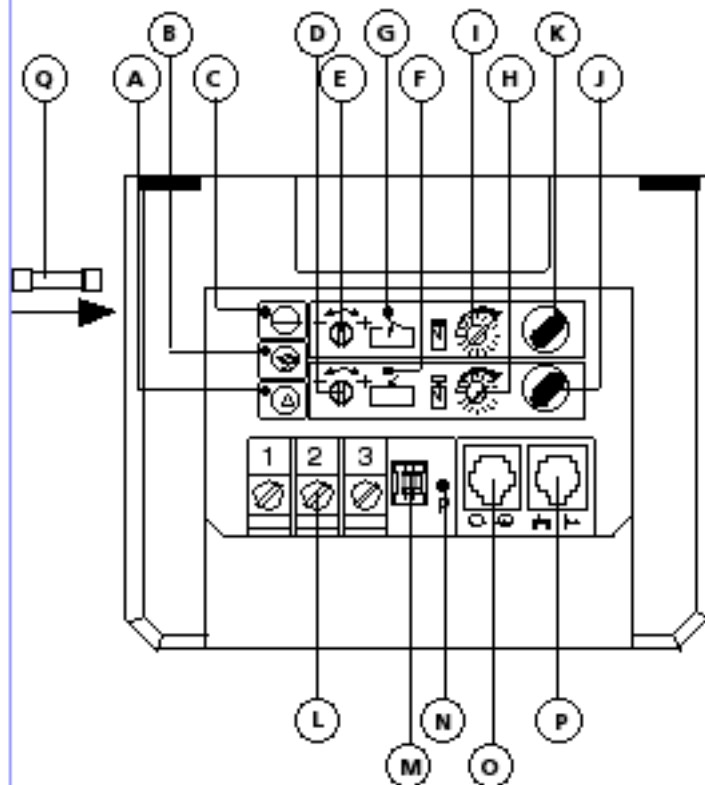

Symbols	Explanation of symbols
	on, mains voltage
	impulse
	malfunction
	Door open
	Door close
	power limit
	external connecting terminals
	2-digit code switch
P	hole for programming button
	stop button
	external control elements
	electronic aerial
	external photocell, transmitter

### Electronic controls:

- |  |   |   |
|--|---|---|
| A indicator                                | lights up red   | - when automatic cut-out actuated<br>- when travel time limit actuated  |
|  | flashes red   | - when external photocell defective or interrupted  |
| B Impulse indicator                        | lights up yellow  | - when button pressed   |
|  | flashes yellow  | - when reference point passed<br>- on valid signal from hand transmitter<br>- programming of remote control                                       |
| C Power supply indicator                   | lights up green   | - when voltage ok   |
| D Travel limit adjusting screw             | "close"   |   |
| E Travel limit adjusting screw             | "open"  |   |
| F Indicator "close"                        | - lights up when closing limit is reached   |   |
| G Indicator "open"                         | - lights up when opening limit is reached   |   |
| H Automatic safety cut-out adjusting screw | "close"   | } The most sensitive setting is at the 12 o'clock position. To return to the previous setting, complete one full turn. (adjustable in 16 stages). |
|  | Turn clockwise for more thrust power.   |   |
| I Automatic safety cut-out adjusting screw | "open"  |   |
|  | Turn clockwise for more pulling power.  |   |
| J Test button                              | "close"   |   |
| K Test button                              | "open"  |   |
| L  | Connecting terminals for external impulse buttons (if installed)                                      |   |
| M 1  | - Programming switch for connecting external "stop" button  |   |
| 2  | - Programming switch for connecting external photocell  |   |
| N  | Hole for programming button for coding the remote control   |   |
| O  | Plug socket for "external control elements"   |   |
| P  | Plug socket for "electronic aerial", "external photocell"   |   |
| Q  | Mains fuse 4 A max. Access possible after disconnecting from the mains and removing the control unit. |   |

15

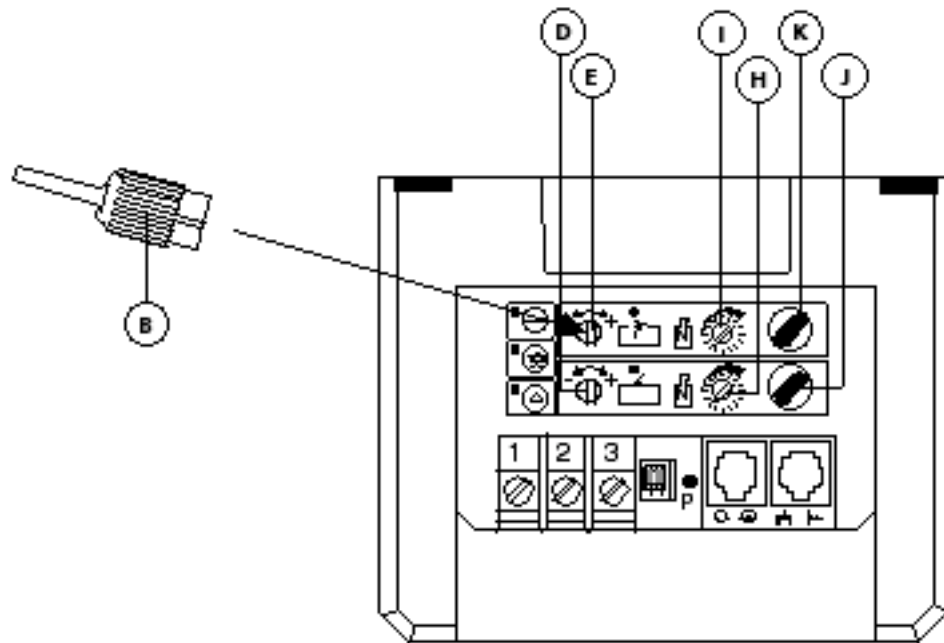

### Test run and adjustment of the automatic safety cut-out:

Connect to the mains and make a test run by activating one of the test buttons (J or K).

The door travels in the corresponding direction and must have reached its final 'open' and 'close' positions (travel limits).

Adjust the automatic cut-out using the adjusting pin clipped to the inside of the front cover.

Adjusting screw I = operating direction "open" (pulling power).

Adjusting screw H = operating direction "close" (thrust power).

Turn clockwise to increase the pulling and thrust power.

To return to the previous setting, complete one full turn (adjustable in 16 stages).

Set the automatic cut-out as sensitive as possible (150 N max.).

Check its function regularly!

### Adjustment of the travel limits:

Using the adjusting pin (B) to turn the travel limit adjusting screws (D or E) = "open" and = "close", the distance of travel can be increased or reduced as required. Turning in the direction of (+) increases the distance of travel whilst turning in the direction of (-) reduces the distance of travel.

The travel limit adjusting screws are notched in stages, one notch representing an adjustment in the distance of travel of approx. 3 mm. As soon as the set travel limits are reached, the corresponding LED's in the electronic control unit light up.

16

### Hand transmitter:

A Flashing battery control

B Operation button

C Battery compartment cover

D 9V battery IEC 6F 22

To change and insert the battery, push the cover (C) to one side and slide back.

When changing the battery, be sure to pole correctly.

Batteries are not covered by the guarantee.

### Attention!

Never use the hand transmitter without making sure that neither people nor objects stand in the travel area of the door.

Keep hand transmitters out of the reach of children!

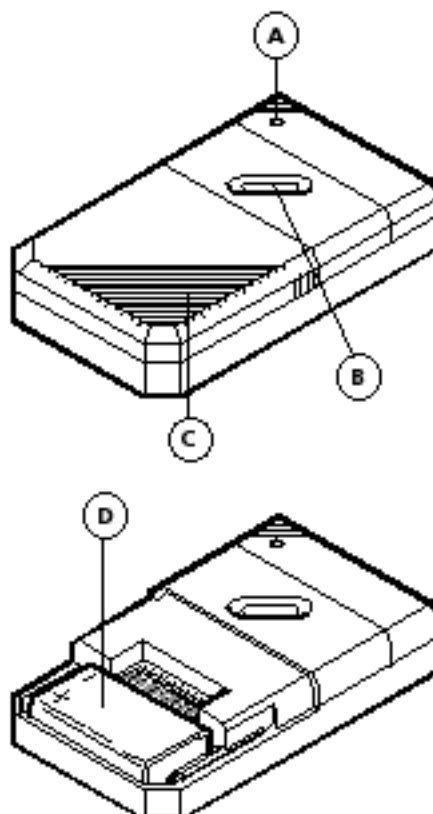

17

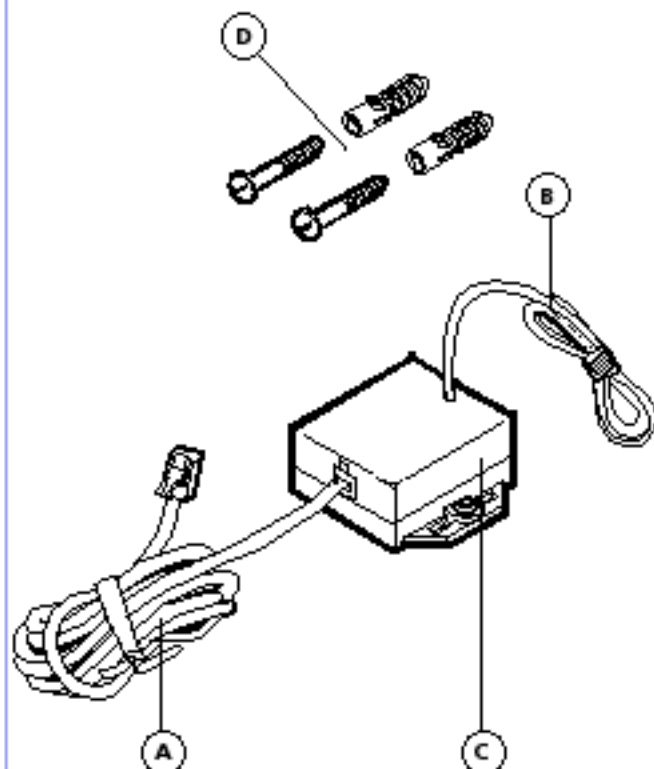

### Electronic aerial:

A Connecting cable to control unit with plug

B Aerial cordon

C Aerial box (with 2 holes for screw mounting)

D Fixings

Plug the connecting plug into the electronic control unit (see fig. 18).

Unroll the connecting cable completely.

After coding and putting the hand transmitter into operation (see figs. 16 and 18), position the box (C) to achieve a good range.

Install away from the door as steel doors have a screening effect. When the optimum range has been achieved, mount the housing to the ceiling or wall.

Roll out the aerial cordon (B) and align it.

The range may vary with different digital security codings.

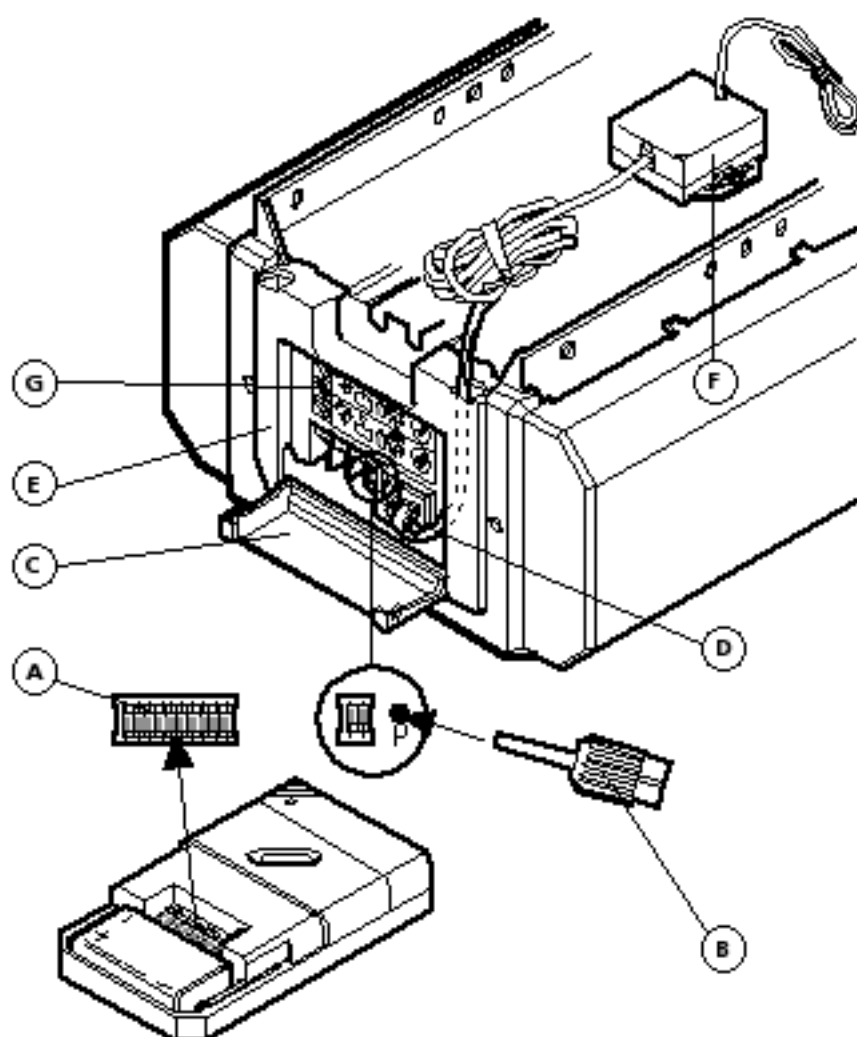

### Connecting the electronic aerial and coding the hand transmitter:

- A 10-digit code switches in the hand transmitter
- B Adjusting pin for setting code switches and programming button P
- C Control unit front cover
- D Connecting plug to electronic aerial
- E Drive unit front panel
- F Electronic aerial
- G Impulse indicator

Open the front cover (C). Feed the electronic aerial connecting cable with plug (D) through the drive unit front panel (E) and plug into the control unit.

There is an adjusting pin inside the front cover for setting the code switches. Set the positions of the 10-digit code switches (A) nos. 1 - 10 in the hand transmitter (personal code). There are 1024 possible codes.

Using the adjusting pin (B) activate the programming button P for approx. 2 seconds until the indicator (G) starts to flash. Code the hand transmitter (in the case of the multi-channel hand transmitter, operate the corresponding button) until indicator (G) starts to flash quickly. The coding is now stored and remains stored even in the event of a power failure.

Operating the hand transmitter again allows the door to be opened or closed.

If after approx. 30 seconds no valid signal has been received from the hand transmitter, the coding procedure is automatically terminated. On completing the coding, close the front cover.

19

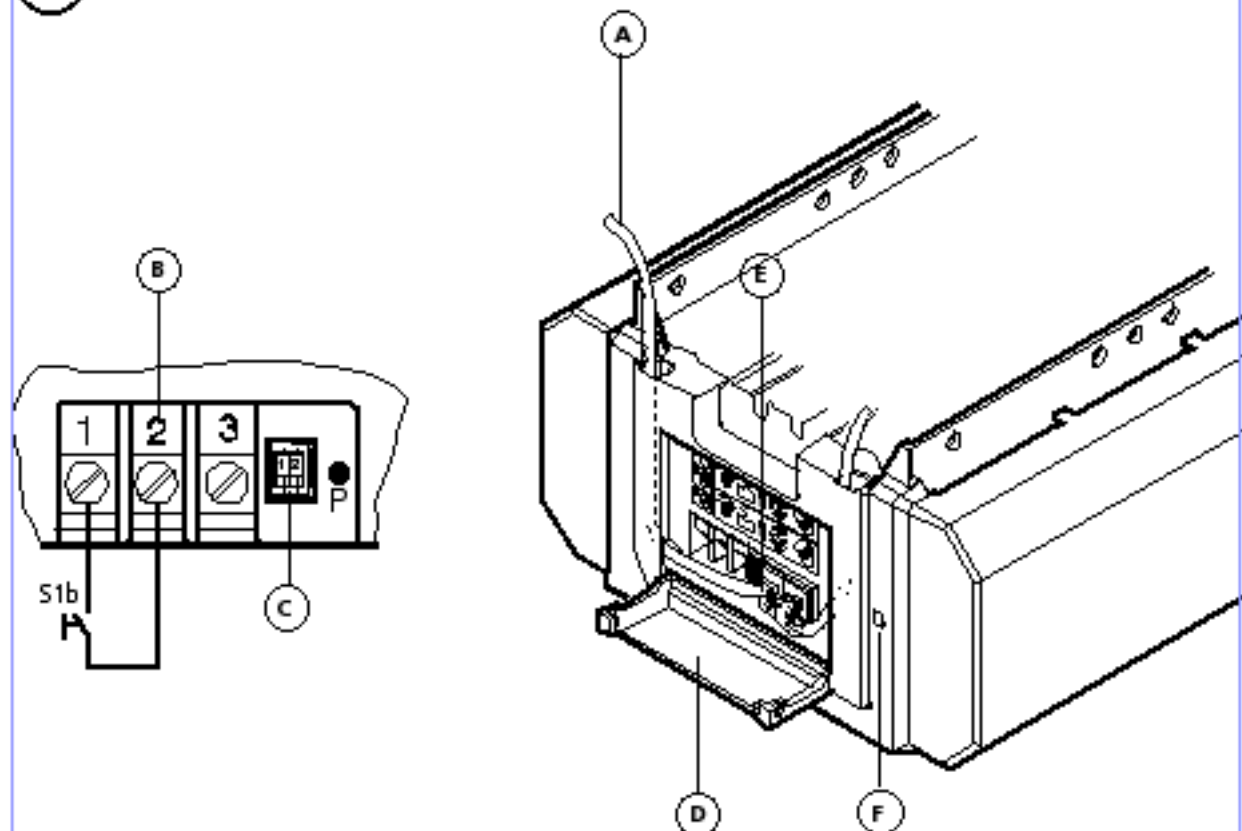





### Connection of external control elements and function of the 2- digit code switch

- A Connecting cable for Marantec control elements (button inside or key switch outside; not included with Comfort 140)
- B Connection of site control elements (metal terminal connections, not included with Comfort 140 - available as accessory)
- C 2- digit code switch
  - 1 - Programming switch for connecting external stop button (e.g. Marantec Command 103, 104 or 201)
  - 2 - Programming switch for connecting external photocell (e.g. Marantec Special 601)
  - If any of above installed, switch corresponding programming switch (C) to "OFF" position.
- D Control unit front cover
- E System plug for control elements (e.g. Marantec Command Series)
- F Drive unit front panel

Open the front cover (D). Push the connecting cable (A) for external control elements with plug (E) through the front panel (F) and plug into the control unit as illustrated or connect site control elements to terminal B. After plugging in the connection plug or connecting the control elements, close the front cover.

Functions of the 2- digit code switch (C):

Switch	Signification
	1 - no external stop button connected 2 - no external photocell connected
	1 - external stop button connected 2 - no external photocell connected
	1 - no external stop button connected 2 - external photocell connected
	1 - external stop button connected 2 - external photocell connected

20

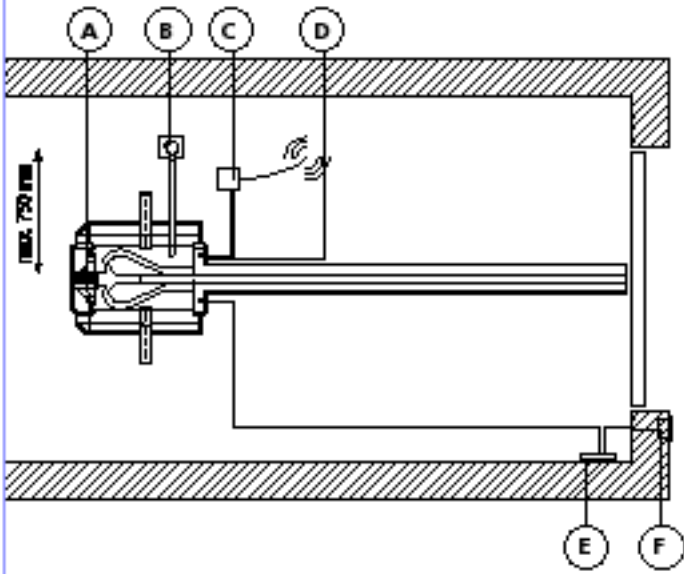

### Cable connecting plan

- A Comfort 140 drive unit
- B Socket with earth contact (Schuko) 220 V- 240 V 50 Hz (on site)
- C Electronic aerial
- D Comfort 140 control unit
- E Command 101 interior keyboard with connecting cable
- F Key switch Marantec Command Series

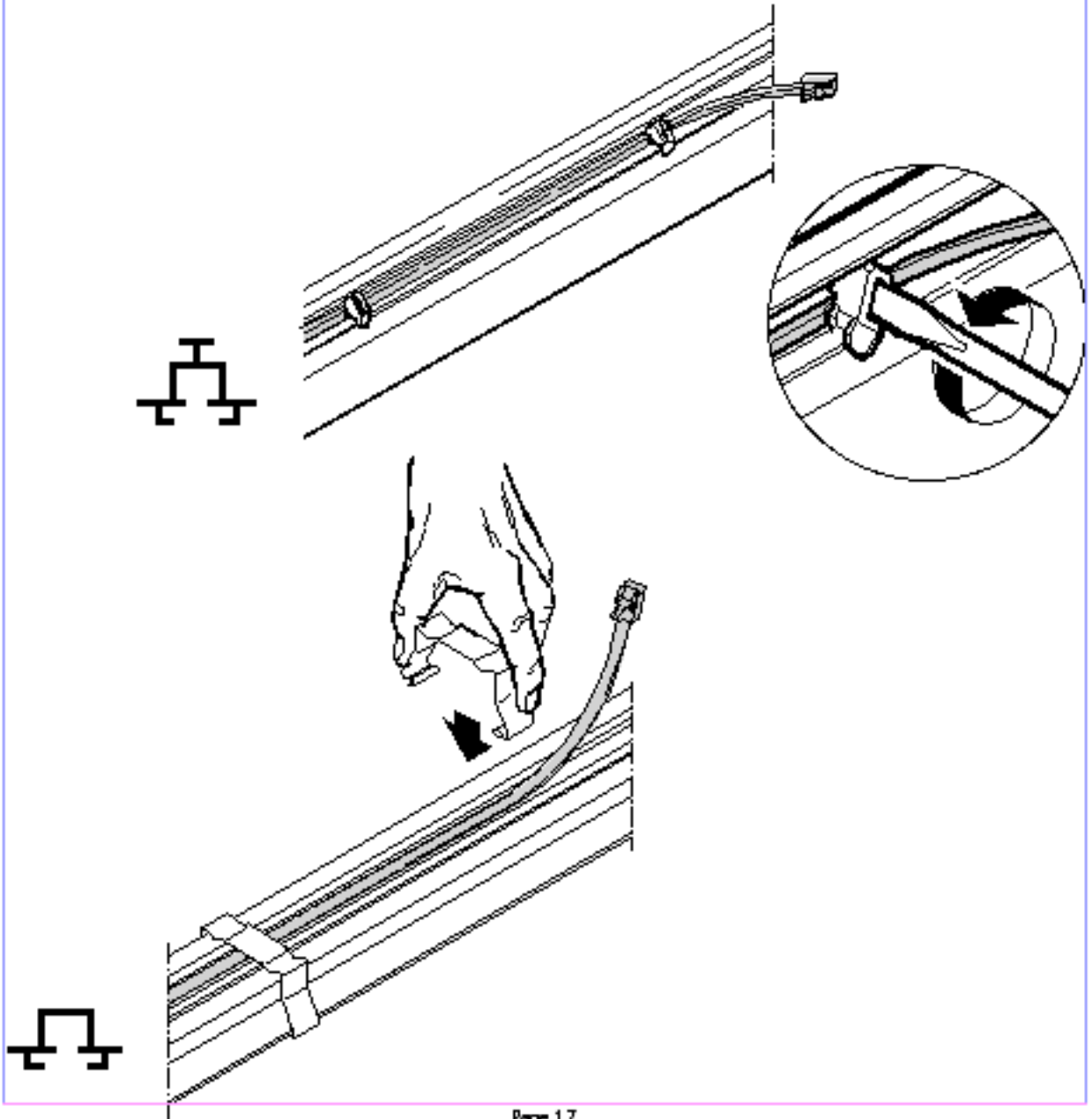

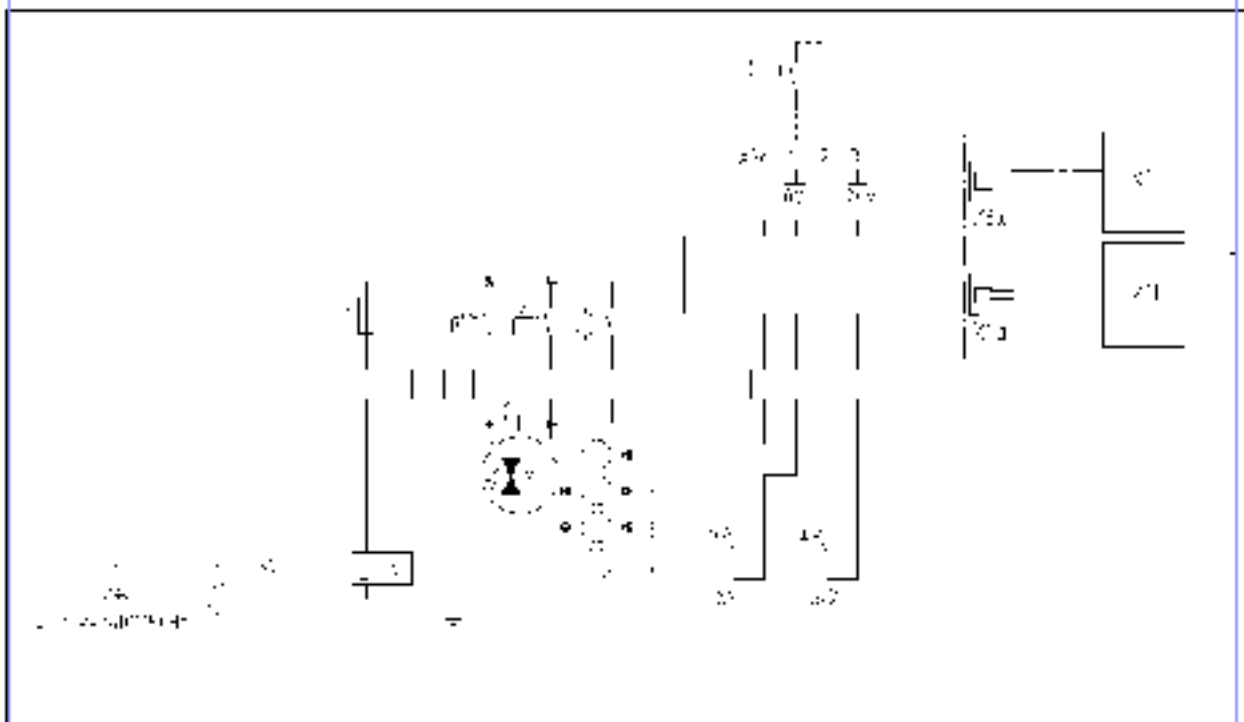

### Circuit diagram B-MC 140

- C Condensator
- F1 Fuse 4 AM
- H1-H4 Operator lighting
- M1 Motor with thermal overload protection
- S Main switch or button "emergency-off" (on site)
- S1b "Impulse" button (on site)
- S21 RPM sensor
- S22 Reference point sensor
- X1 Socket with earth contact (on site)
- X2 Safety plug
- X3a Plug socket for control elements Marantec Command Series
- X3b Control elements Marantec Command Series
- X3c Connecting terminals for "impulse" button (on site)
- X4a Plug socket for electronic aerial
- X4b Electronic aerial

**IMPORTANT!** Low voltage!  
External voltage at the plug sockets X3a, X4a or screw terminals X3c will completely destroy the electronics.

**IMPORTANT!** Observe local safety regulations!  
Always lay mains cable and control cable separately.

## Test Instructions (only for the specialist)

### Troubleshooting:

Fault	Cause	Remedy
No green light.	No voltage.	Check mains supply. Check socket. Check operator mains fuse (see fig. 14/Q).
	Thermal protection in the motor is activated.	Allow motor to cool down.
	Control unit is defective.	Cutoff mains supply to drive. UnscREW control unit and pull slightly forward, withREW connecting plug and remove. Have control unit checked.
Red light glowing.	Automatic cut-out set too sensitively. Door operation too sluggish. Door blocks.	Re-set adjusting screws (fig. 14/I "open" direction, fig. 14/H "close" direction) by turning clockwise to make automatic cut-out less sensitive. Ensure door moves easily.
	Drive is blocked mechanically.	Cutoff mains supply to drive. Turn drive shaft with screwdriver through the opening above the lamp cover. Have drive unit checked.
Red light flashing slowly.	External photocell defective or interrupted.	Remove obstacle or have photocell checked.
No reaction on impulse.	Connecting terminals for "impulse" button bridged, e.g. due to short-circuit or wrong terminal connection.	Temporarily isolate cabled key switches or interior push buttons from control unit. Remove plug (fig. 14/C) and look for cable fault.
	Programming switch for stop button (see fig. 19/C) switched on but stop button not connected.	Switch over programming switch (fig. 19/C) or connect stop button (opener).
Drive only operates in "open" but not in "close" direction.	Programming switch for photocell (see fig. 19/C) switched on but photocell not connected.	Switch over programming switch (fig. 19/C) or connect photocell.
Yellow light not flashing quickly on impulse from hand transmitter.	Electronic aerial disconnected.	Connect aerial to control unit (fig. 18).
	Hand transmitter wrongly coded.	Re-code in accordance with fig. 18.
	Flat battery.	Insert new 9 V battery EC 6F22 (fig. 16). Flashing LED in transmitter indicates battery condition.
	Hand transmitter, control unit or electronic aerial defective.	Have all 3 components checked.
Insufficient range of hand transmitter (less than 5 m).	Flat battery.	Insert new 9 V battery EC 6F22 (fig. 16). Flashing LED in transmitter indicates battery condition.
	Wrongly positioned electronic aerial.	Re-position the aerial box. Ensure the cable connecting to the control unit is rolled out at full length. Position well away from the door. Mount the aerial to the side or back in an opposite direction to the boom. Also align the aerial cord and, if possible, let it hang freely.
Both red and yellow lights flashing.	RPM sensor defective.	Have drive unit checked.
Red and yellow lights flashing alternatively.	Fault in control unit.	Have control unit checked.

23

## Commissioning

Power operated windows, doors and gates for industrial use must be checked by a specialist after initial installation and then regularly at intervals of 1 year minimum.

## Maintenance

The Marantec Comfort 140 Door Operator is virtually maintenance-free. However, all movable parts of the door and operator system should be checked regularly and kept in an easily movable condition. The door must be easy to operate manually. The separate door counter/balance mechanism must be checked regularly.



EN 55011  
EN 50081  
EN 50082  
ETS 300220

Changes reserved!

Status: 08/06