

V3E Control Board Installation Instructions

(Stock Code: 40-5413)

WARNING! Read these instructions **FULLY** before use. Installation should only be carried out by a **COMPETENT** installer.

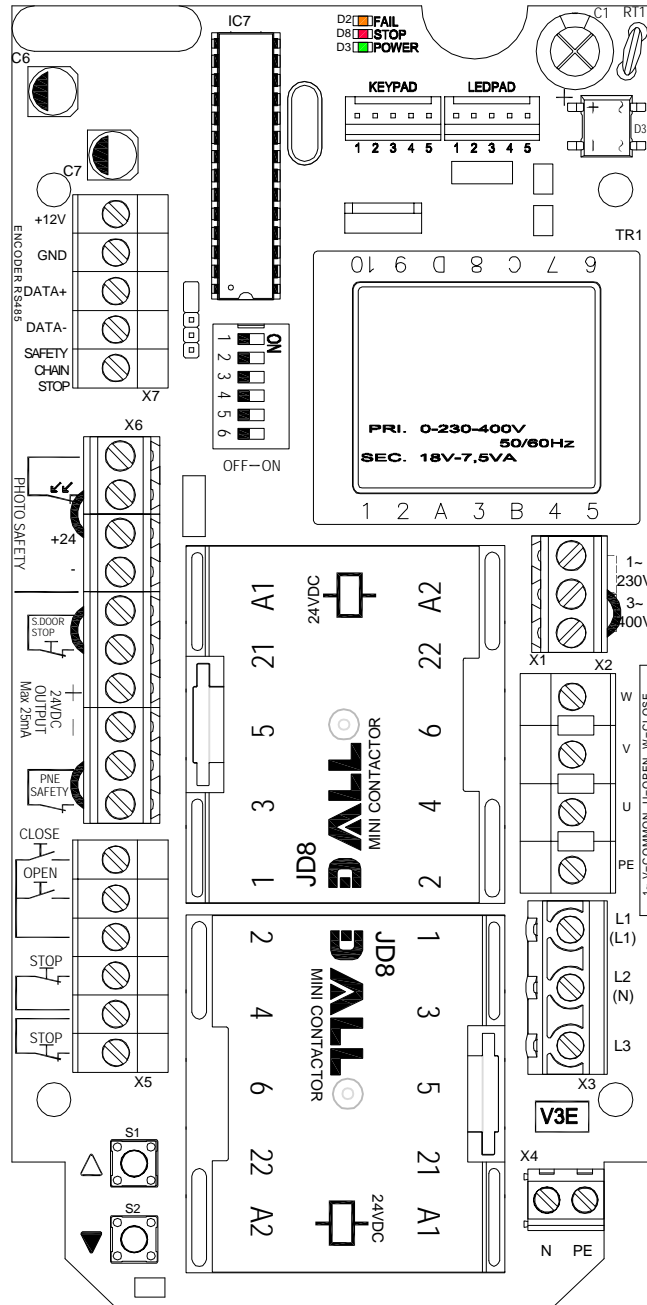

DISCLAIMER: Link Controls Ltd. constantly strives to improve the quality of its goods and as such reserves the right to replace/modify products without prior notification. Any examples given are intended for guidance only.

T: +44 (0)1928 579050
 F: +44 (0)1928 579259
 www.linkcontrols.co.uk
 sales@linkcontrols.co.uk

Link Controls
Marantec

Drawing No:- LC-2937	Page No:- 1 of 12
Revision No:- A	Rev Date:- 26/01/11
Drawn By:- R.A.H.	Date:- 20/10/10
Checked By:- A.M./J.C.	Appr' By:- S.L.

Stuart Rd, Manor Park, Runcorn, Cheshire, WA7 1TS

Operation

The door may be opened & closed in Deadman mode using either the test pushbuttons during installation or the remote pushbuttons during normal operation with selectable Deadman or Impulse mode. (See D.I.L. Switch Settings on page 5 for further information).

If a safety device is actuated during the closing cycle, then the door will stop for approximately 0.5 seconds before returning to the Fully Open position. Once the obstruction has been removed, the door will attempt to close if either a close signal has been given or after the pre-set time (Default: 15 seconds) if the Automatic Return function has been selected.

Maintaining I.P.54 Environmental Protection Rating

TO MAINTAIN THE BEST PROTECTION AGAINST WATER / MOISTURE IT IS RECOMMENDED THAT **ALL** OF THE ENTRIES ARE MADE VIA THE BOTTOM OF THE ENCLOSURE.

1. When cabling, ensure that the correct cable gland size is used with an appropriately sized sealing ring.
2. Under **NO** circumstances must an unsecured cable enter the panel through a grommet.

Installation Instructions

1. Knockouts are provided for cable entry, which can be removed as required.
2. For wall mounting, remove the control panel cover via the four fixing screws.
3. Mark up the mounting hole centres at a suitable height & location, which is free from excessive vibration.
4. Drill holes for plugs and Ø4mm fixing screws.
5. Ensure that the control panel is free from debris (swarf, dust, etc.) before wall mounting.
6. Refer to wiring instructions.

Note:-

All connections to the control panel **MUST** be made in accordance with the connection diagram and all terminations **MUST** be securely tightened.

WARNING! Ensure power to the V3E is **OFF** before removing the control panel cover.

3ph Phase Reversing Industrial Plug (Red) - If fitted (415VAC Pre-wire ONLY)

To change the operator rotation direction:-

1. Disconnect the plug from the socket.
2. Place a large, flat bladed screwdriver into the slot provided.
3. Press down and rotate the pins through 180°.
4. Reconnect the plug back into the socket.

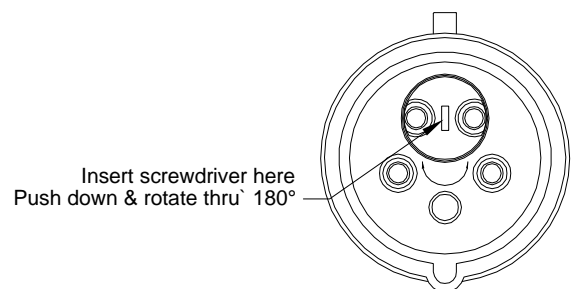

Open & Close Test Pushbuttons

"OPEN" Test Button

Press to Open the door whilst setting the limits. Ensure door travels in the correct direction.

"CLOSE" Test Button

Press to Close the door whilst setting the limits. Ensure door travels in the correct direction.

V3E Control Board Layout

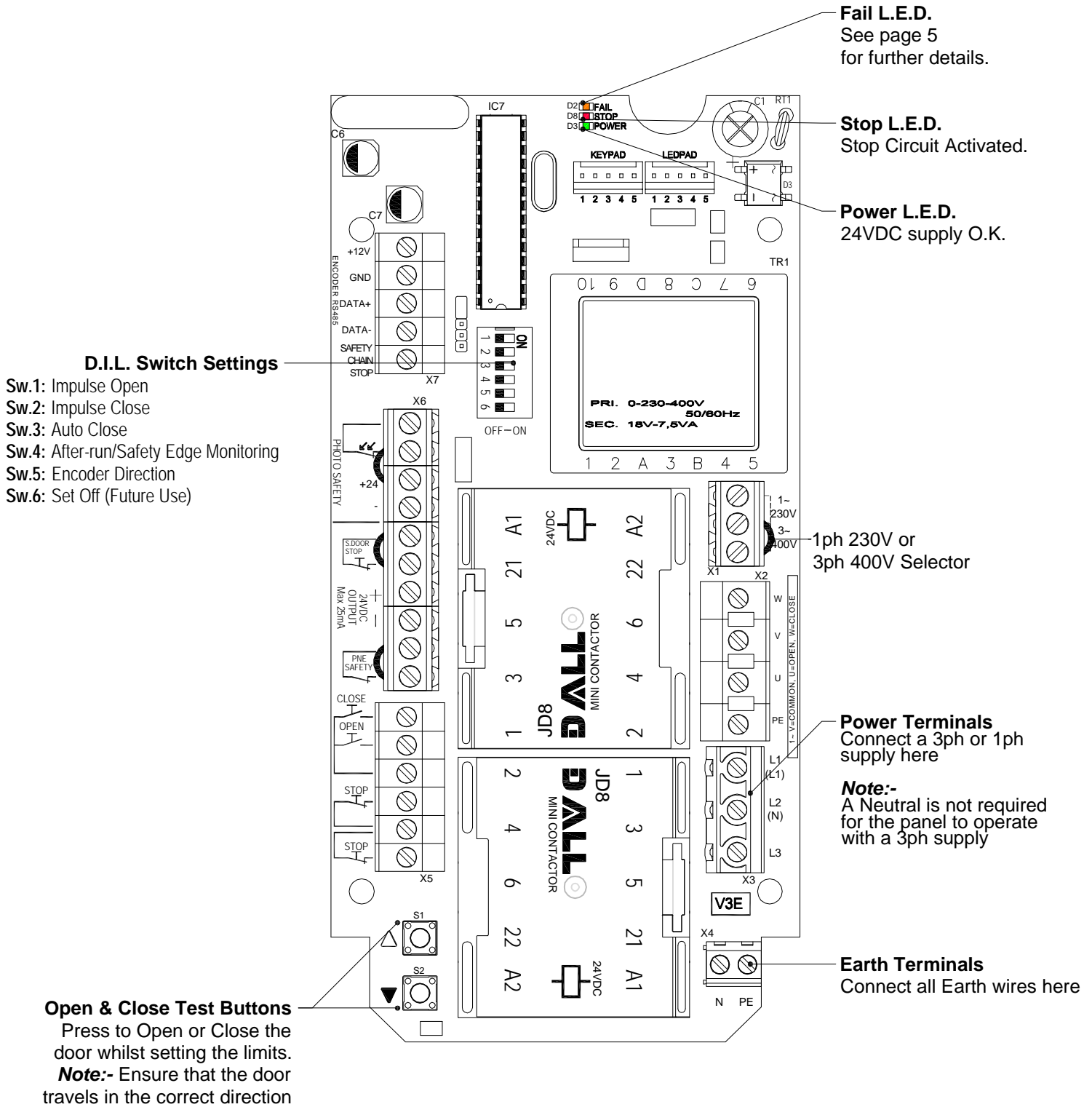

D.I.L. Switch Settings

Operation Mode

The Door Operating Mode is set via Dip-Switches:

Sw.1 & Sw.2: Deadman / Impulse Open / Close

When enabled, it activates Impulse Open operation (Press & Release)

Sw.1	Sw.2	Mode
OFF	OFF	Deadman Open, Deadman Close
ON	OFF	Impulse Open, Deadman Close
OFF	ON	Deadman Open, Impulse Close
ON	ON	Impulse Open, Impulse Close

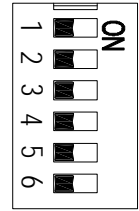

OFF – ON

Note:- Move required D.I.L. Switch right to set to **ON** & enable option.

Sw.3: Variable Auto-Close Timer (Default 15 seconds)

Enables the Variable Auto-Close Timer, which is fully adjustable between 1-240 seconds

Note:- This function can only be selected with Sw.2 in the ON position.

Sw.3	OFF	Auto-Close Disabled
	ON	Auto-Close Enabled

Setting the Variable Auto-Close

1. Turn D.I.L. Switch 3 to ON & Run the door to the Fully Open position.
2. Press and hold the 'OPEN' & 'CLOSE' pushbuttons together for 5 seconds.
3. The Red, 'STOP' L.E.D. will flash to indicate learning mode.
4. Press the 'CLOSE' pushbutton once the required time has elapsed.
5. The new Auto-close time has been set.

Note:- If the V3E is left in learn mode, the Auto-close time will default to 15s (Factory pre-set).

Sw.4: Afterrun/Safety Edge Monitoring (Pneumatic Safety Edge Only)

When enabled, it activates the Afterrun function, which uses the Close limit (set 50mm from the floor) as a safety edge override limit. When the Closed limit is activated the operator electronically overruns this limit (0.3s max.) until a signal from the safety edge is received. If no safety edge signal is received, the 'Safety Fail' L.E.D. will flash and the door will fail to Deadman Mode. To reset, simply close the door fully until a safety edge signal is received.

Sw.4	OFF	Afterrun/Safety Edge Monitoring Disabled
	ON	Afterrun/Safety Edge Monitoring Enabled

Sw.5: Encoder Direction

For normal conventional motor mounting this switch would normally be in the off position.

For reverse mounted operator then turn this switch to the 'on' position.

Sw.6: Not Used

This switch must be left in the off position.

Programming

Programming Limits

IMPORTANT! The CLOSE limit must be set first.

If limit positions are not programmed the door cannot be operated.

To enter limit programming mode press the OPEN and STOP pushbuttons together for a minimum of 10 seconds. The L.E.D. will flash while in programming mode.

The door will now be in 'PUSH TO RUN' mode in both the OPEN and CLOSE directions.

First, run the door to the CLOSE position and press the STOP pushbutton to save the CLOSE LIMIT position.

Now run the door to the OPEN position and press the STOP pushbutton to save the OPEN LIMIT position.

The L.E.D. will stay on for 1 sec to indicate the end of programming mode.

The door is now ready for operation. (**Note:** The L.E.D. will stop flashing).

Reprogramming

Reprogramming mode can be entered by pressing OPEN & STOP pushbuttons simultaneously for a minimum of 10 secs.

Both limits can be reprogrammed - It is important to always start with the closing limit.

The L.E.D. will flash while in learn mode.

Fault Diagnostics

Flashing L.E.D. (Fail) And Service L.E.D. (X12)	Fail Description	Possible Cause / Action
1	No answer from encoder	Check connections Maybe Interchange RS485 A and B
2	Limits not Programmed	Program Limits
3	Not in use	
4	Calculation failure	Check D.I.L. SW.5 (Left/right turning). Possible user failure - both limits are set the same. Encoder failure.
5 & 6	Not in use	
7	Encoder = position out of programmed area D.I.L. SW.5 is changed by a failure Kostal encoder - mechanical failure	Try reprogramming Kostal: Try changing turn direction on D.I.L. SW.5 or change encoder. Power up will reset this fail
8	Kostal encoder - Failure in power supply	Check connections and power. Maybe change encoder

Priority: Normal Run:

Flashing L.E.D. (Fail) = Edge monitoring fail indication.
 Fixed light = If photo or PNE is activated when close P/B is activated.
 Fixed light = Position failure - encoder position is not moving (without P/B active)

Flashing Red PCB L.E.D. = Auto close time not set.
 Fixed light = Stop activated.

Option service L.E.D. = Service L.E.D. output on X12-4

Terminal Connections

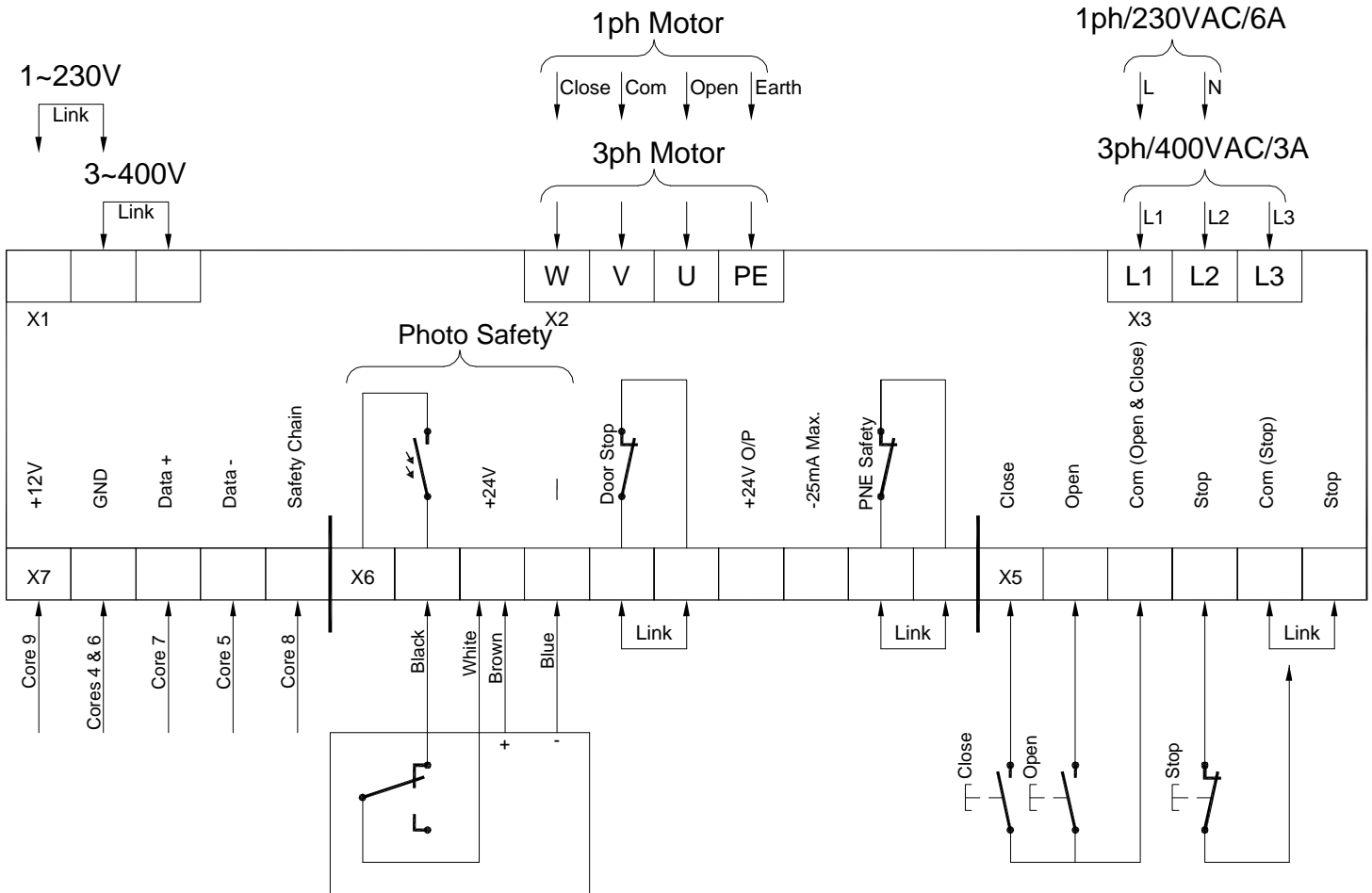

Power Connections

Motor:

Connect a suitable motor to terminals `U`, `V`, `W` & `PE` as illustrated.

Power Supply:

Check that the power supply is suitable - either option a) or b):

The mains supply **MUST NOT** exceed $\pm 10\%$ of the nominal supply voltage.

The supply breaker should be suitably sized in order to protect the motor and should not exceed 6A.

IMPORTANT! Ensure voltage link is correct i.e. 230VAC or 400VAC (Default)

Control Connections

Remote Pushbutton:

Open, close and stop connections on X5 are available for connection of a second push button station (Stock Code: 37-3015). pushbutton station would need to be wired as shown with 5 cores.

Safety Edge:

Remove the link between terminals PNE SAFETY and connect a safety edge system.

If a safety edge evaluation unit is being used then only one photocell may be powered from the V3E.

Any Additional photocell should be powered from a separate power supply.

Limits: (None pre-wired version ONLY)

Wire encoder as shown above and see encoder details on page 8.

24VDC Output:

A 24VDC @ 25mA Max. output is available as shown for auxiliary equipment.

Electronic Cycle Counter

The counter indicates only one digit at a time (i.e. 10's; 100's; 1,000's; 10,000's or 100,000's).

Counter State: When the door is closed, press and hold both the 'OPEN' & 'CLOSE' pushbuttons together.

'STOP' L.E.D.: Indicates the active digit 10ⁿ (e.g. 10¹, 10², 10³, 10⁴ or 10⁵)

'FAIL' L.E.D.: Indicates the number of multiples of the digit in question.

Next Digit: Pressing the 'OPEN' pushbutton will progress the display to indicate the next digit.

Previous Digit: Pressing the 'CLOSE' pushbutton will return the display to indicate the previous digit.

Return to Normal Run: Pressing the 'STOP' pushbutton will return the starter to normal operation.

Example: A door, which had opened 462 times, would indicate the following:-

1's are NOT shown.

The counter will default to showing Tens: 10¹ x 6 = 10 x 6 (i.e. Active digit 10¹):

'STOP' L.E.D.: Rd ⊗ Repeats Rd ⊗ Repeats Rd ⊗ etc.

'FAIL' L.E.D.: Ye ⊗ ⊗ ⊗ ⊗ ⊗ Ye ⊗ ⊗ ⊗ ⊗ ⊗ Ye ⊗ ⊗ ⊗ ⊗ ⊗

Press the 'OPEN' pushbutton to indicate next digit, Hundreds: 10² x 4 = 100 x 4 (i.e. Active digit 10²):

'STOP' L.E.D.: Rd ⊗ ⊗ Repeats Rd ⊗ ⊗ Repeats Rd ⊗ ⊗ etc.

'FAIL' L.E.D.: Ye ⊗ ⊗ ⊗ ⊗ Ye ⊗ ⊗ ⊗ ⊗ Ye ⊗ ⊗ ⊗ ⊗

Press the 'STOP' pushbutton to return to normal operation.

Intelligent Pushbutton Station

IMPORTANT!: To ensure correct operation, this Pushbutton Station **MUST** be installed in this orientation.

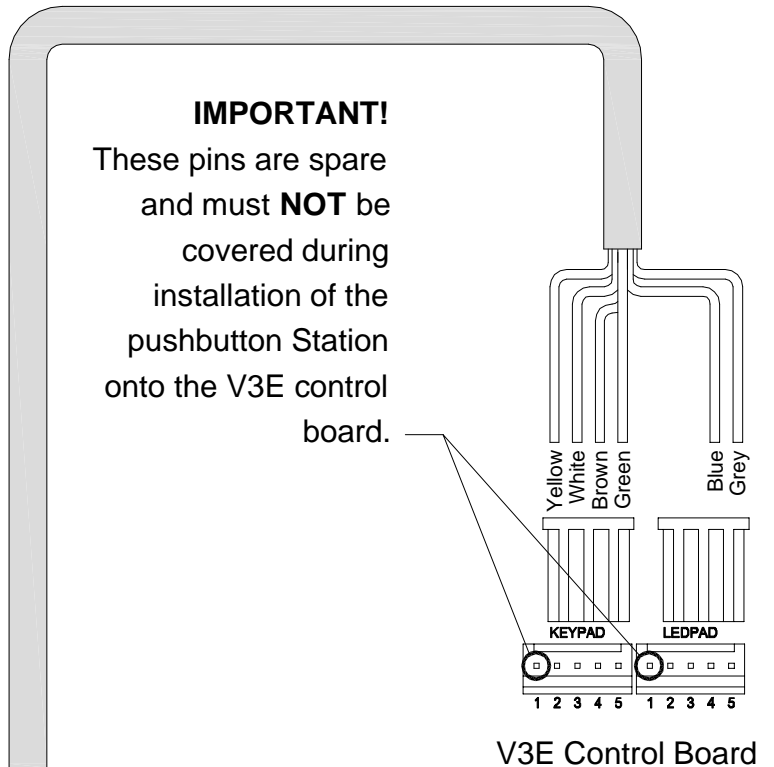
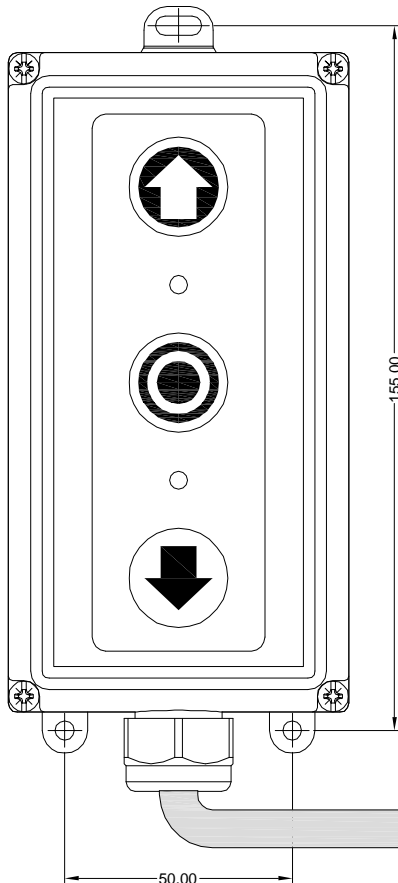

Photocell Connections

1. Connect a N/C contact from the Photocell to terminals as shown.
2. Connect the power leads of the Photocell to terminals '+' & '-', observing polarity.

Caution! It is not recommended to power more than two photocells from this supply.

Note:- In order to comply with current regulations, a photocell may only be used in conjunction with a monitored safety edge (i.e. wired in series) and NOT as a stand-alone device.

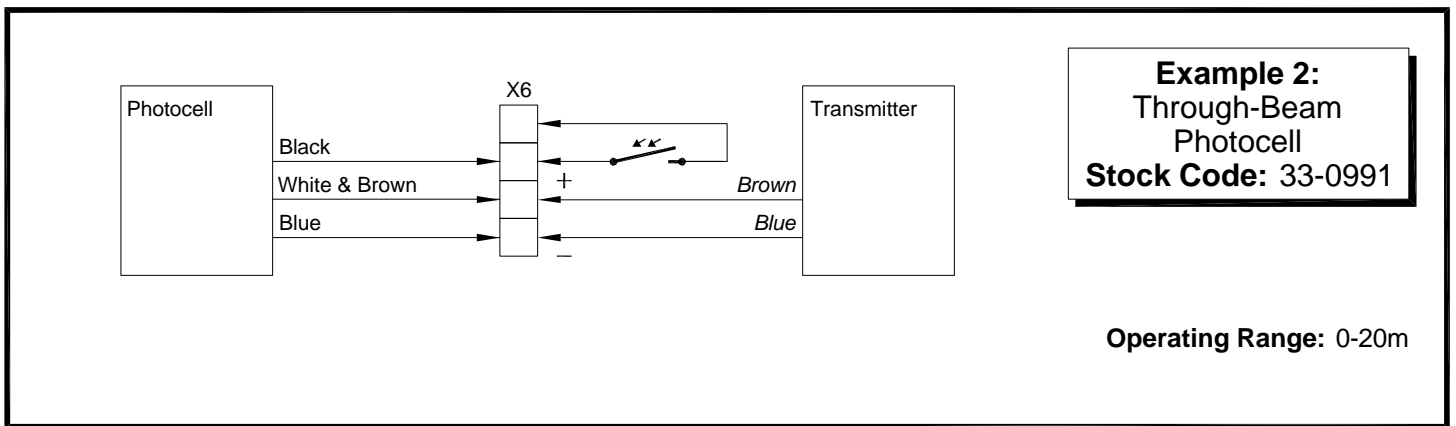
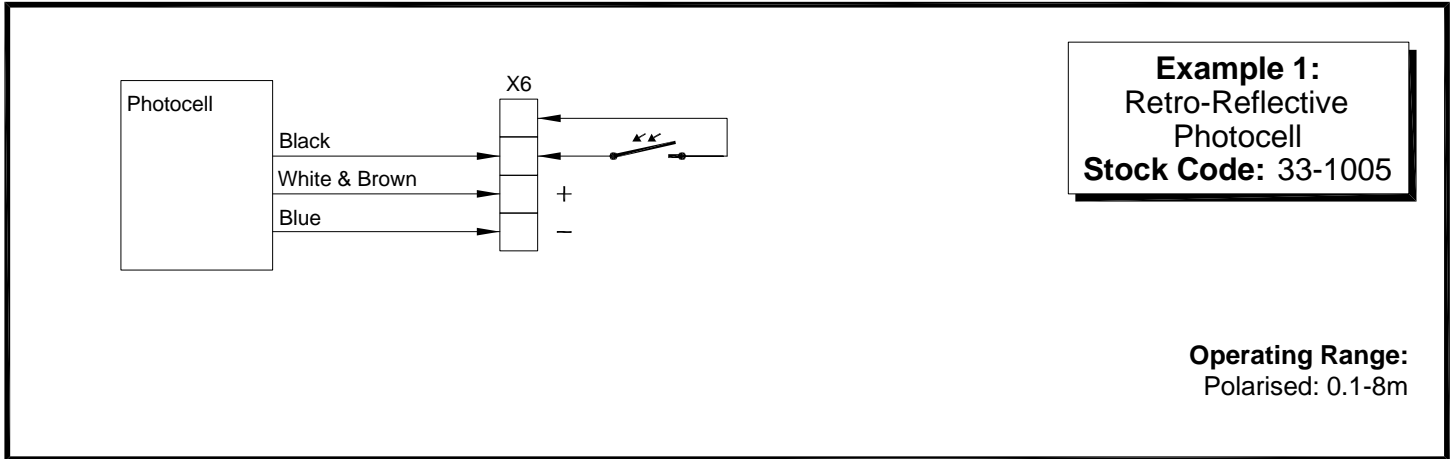

Note:- Please see Drawing No. LC-0255 for more detailed information.

Optional 2-Channel Radio Card (Stock Codes: RR.2WBPA & RR.2WBVA)

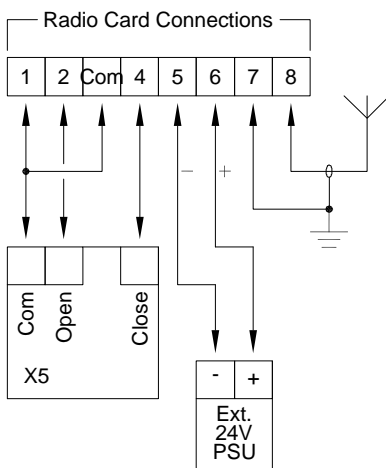

Kostal Encoder (Stock Code: 40-4006)

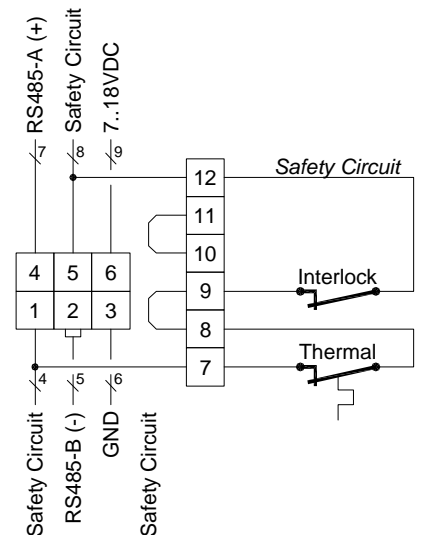

2-Channel Radio Receiver Instructions

Circuit Board Layout

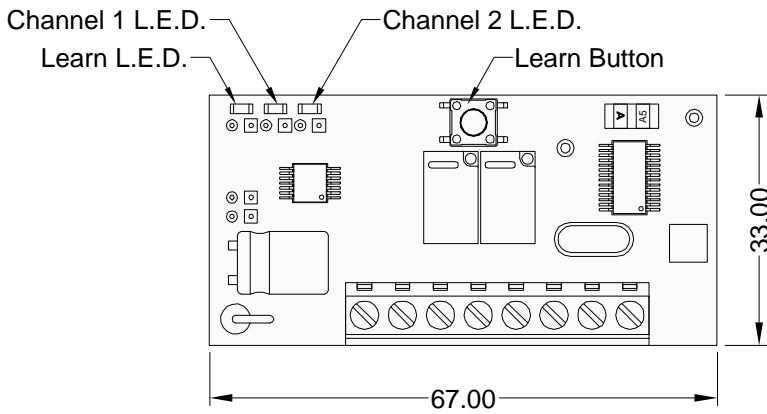

Type

Model	Channels	Code
RR.1WBPA	2	Fixed
RR.2WBVA	2	Rolling

Technical Data

Frequency	433.92 MHz
Antenna	Tuned
Power Supply	24VDC
No. of Tx. Codes (Fixed/Rolling)	16/32
Range	30-100m
Channels	2
Relay Contact	1A, 24VDC

Installation

To optimise reception, install the antenna far away from obstacles & metal structures. Avoid positioning several receivers together. **Note:-** If no antenna is used, reception will be considerably reduced.

Programming Handsets into the Receiver

Channel 1:

1. Press the 'Learn' button once. The red 'Learn' L.E.D. and red 'Channel 1' L.E.D. will light.
2. Press the transmitter button of the handset to be learnt once.
The red 'Channel 1' L.E.D. will flash 3 times to confirm that the code learning process was successful.
3. Press the transmitter button of any extra handsets with confirmation as above, or skip to Step 4.
4. Press the 'Learn' button twice to exit Programming mode.

Channel 2:

1. Press the 'Learn' button twice. The red 'Learn' L.E.D. and green 'Channel 2' L.E.D. will light.
2. Press the transmitter button of the handset to be learnt once.
The green 'Channel 2' L.E.D. will flash 3 times to confirm that the code learning process was successful.
3. Press the transmitter button of any extra handsets with confirmation as above, or skip to Step 4.
4. Press the 'Learn' button twice to exit Programming mode.

Note:- If extra handset DIP codes match those previously learnt then no further programming is required.
- WBPA version ONLY

Programming Sequence

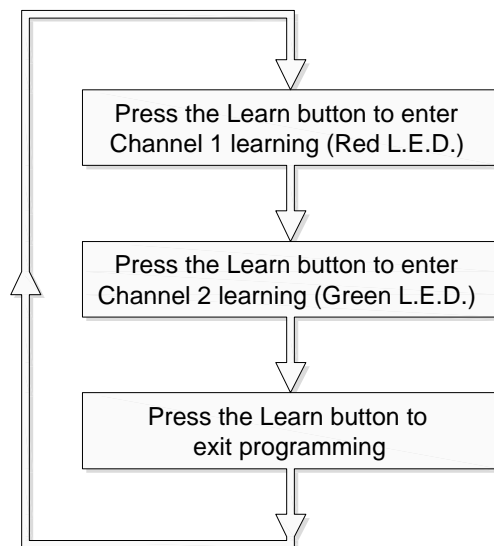

Erasing the Memory

1. Remove power to the receiver.
2. Re-apply the power whilst simultaneously depressing the Learn button.
3. Continue to hold the 'Learn' button for 10 seconds. The memory is erased and the Learn L.E.D. will light.

Note:- For full details of the 2-Channel Radio Receiver Card, please request Drawing No. LC-2753 Rev.B.

24V Optical Safety Edge Evaluation Unit (Stock Code: 33-2117)

Enclosure Layout

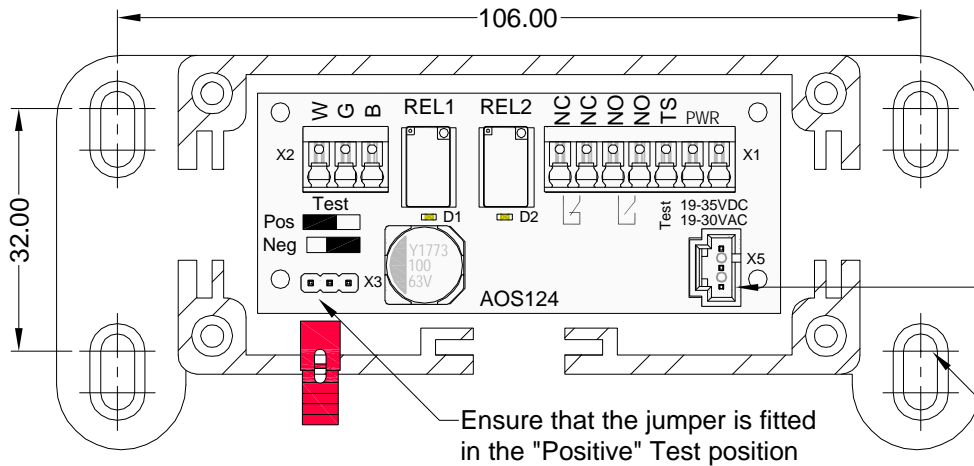

Rubber Seals

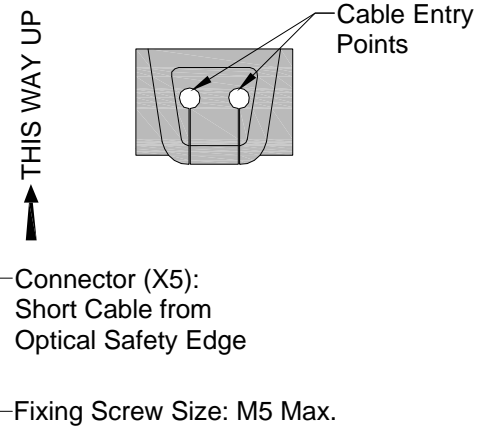

TO PREVENT WATER/MOISTURE INGRESS ENSURE CABLE ENTRIES ARE MADE FROM BELOW

Technical Data

Power Supply	19-35VDC / 19-30VAC
Power Consumption	<35mA w/o sensors
Degree of Protection	IP65
Relay Changeover Contact	125VAC, 60VDC, 0.5A
Opto Connection	White: 0V/Gnd Green: Signal Input Brown: +12VDC/30mA max.
Relay Contacts	NC: Contacts Closed when safety edge activated NO: Contacts Open when safety edge activated
Operating Temperature	-20°C...55°C

Connections

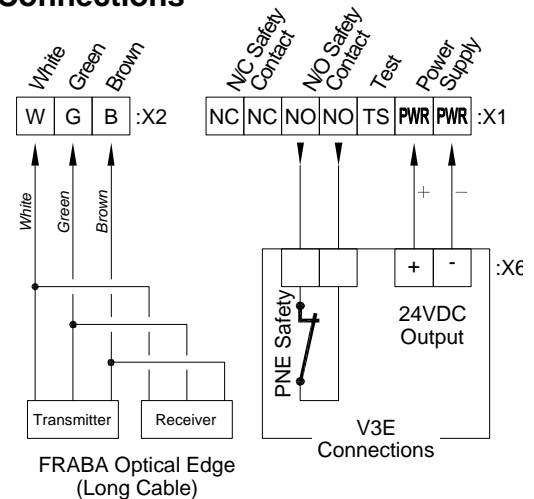

Description

The Optical Safety Edge Evaluation Unit is designed to work with any FRABA compatible optical edge. The unit is designed to go at either end of the spiral cable.

Cable Entry / Installation Instruction Using Rubber Seals (Shown above - Supplied)

1. Remove the lid & rubber seal from the junction box.
2. Whilst taking care not to damage the seal, use a suitable tool to break through the cable entry points. Only use the seals that are required, otherwise the integrity of the junction box will be compromised.
3. Insert the cable into the slot provided in the rubber seal as required.
4. Push the seal (complete with cable) into the housing seat of the junction box.
5. Plug the cable connector into the required board socket, following the instructions for your application.
6. Place the lid on the junction box and tighten the screws to seal the junction box.

Installation Instructions

1. Plug the optical safety edge transmitter into the Molex connector (Ref.:X5).
Note:- The transmitter is the optical eye with the shorter cable.
2. Cut the optical receiver sensor cable to the required length to suit the door.
3. Insert the cores into the appropriate spring-clamp terminals, as shown in the diagram above.
Note:- To connect wires into the spring-clamp terminals, insert a screwdriver into the slot above each opening and push down & hold whilst inserting the wire into the cable entry. Hold the cable firmly in place and then release the screwdriver. Ensure that the terminal has firmly gripped the cable.
4. Insert the spiral cable, via the cable gland fitted to the lid of the box. Terminate cores, as shown.
Note:- If the integral strain relief of the cable gland's locknut interferes with the operation of the door (e.g. photocell), then the locknut can be exchanged for one taken from a standard M16x1.5mm gland.

Declaration of Incorporation

Product: Control Board

Type: V3E

Version: N/A

Declaration is in compliance with:

Machinery Directive 98/37/EC, meeting the Essential Health & Safety Requirements relating to the Design and Construction of Machinery and also the Supply of Machinery (Safety) Regulations, as implemented in the United Kingdom.

Declaration: The equipment supplied by Link Controls Ltd. when installed and maintained according to all the Manufacturer's instructions, in combination with the completed machinery or system that has also been installed and maintained according to all the Manufacturer's instructions, meets the requirements of the Machinery Directive 98/37/EC.

I, the undersigned, hereby declare that the equipment specified above and any accessory listed in the manual conforms to the above Directives and Standards.

Name: Andy Molloy

Signature: 

Position: Technical Director

The machinery to which this Declaration of Incorporation relates must not be put into service until the relevant machinery into which it is to be incorporated has been declared in conformity with the provisions of the Machinery Directive 98/37/EC, as amended, and the national legislation related to its implementation.